

6	5	4
Model	JMSX-40L	
Surface Size	40 x 40mm	
Travel Range	14mm	
Travel Guide	Linear guide	
Resolution	2 μ m (Full step)	
Max. Speed	10mm/sec (based on 5phase motor)	
Applicable Ball Screw	\varnothing 6, lead 1 (C5/C7)	
Accuracy	7 μ m(C5) / 12 μ m(C7)	
Bi-Repeatability	\pm 1.5 μ m(C5) / \pm 3 μ m(C7)	
Load Capacity	7 Kgf	
Parallelism	20 μ m	
Driving Parallelism	10 μ m	
Staightness	5 μ m	
Weight	0.5Kg	
Material	Steel	
Finish Treatment	Electroless Nickel Plating	

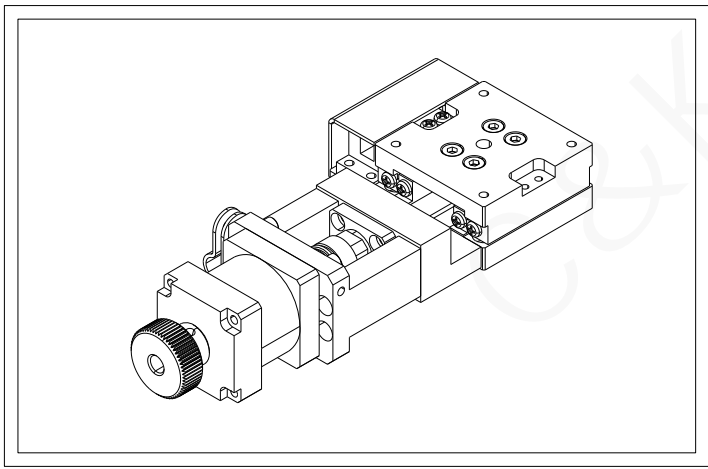

JMSX - 40L
 东莞市诚鲲五金电子科技有限公司
 sales01@dck-gd.com

6	5	4	3	2	1
Model	JMSX-40R				
Surface Size	40 x 40mm				
Travel Range	14mm				
Travel Guide	Linear guide				
Resolution	2μm (Full step)				
Max. Speed	10mm/sec (based on 5phase motor)				
Applicable Ball Screw	Ø6, lead 1 (C5/C7)				
Accuracy	7μm(C5) / 12μm(C7)				
Bi-Repeatability	±1.5μm(C5) / ±3μm(C7)				
Load Capacity	7 Kgf				
Parallelism	20μm				
Driving Parallelism	10μm				
Staightness	5μm				
Weight	0.5Kg				
Material	Steel				
Finish Treatment	Electroless Nickel Plating				

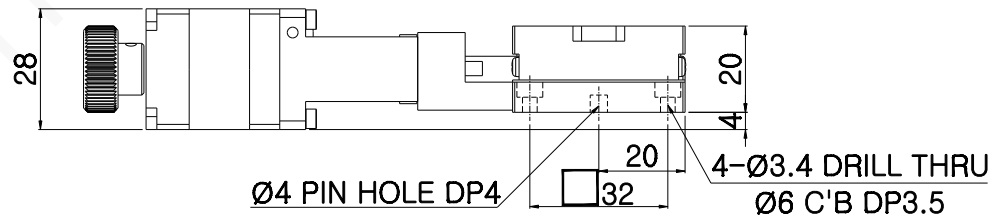
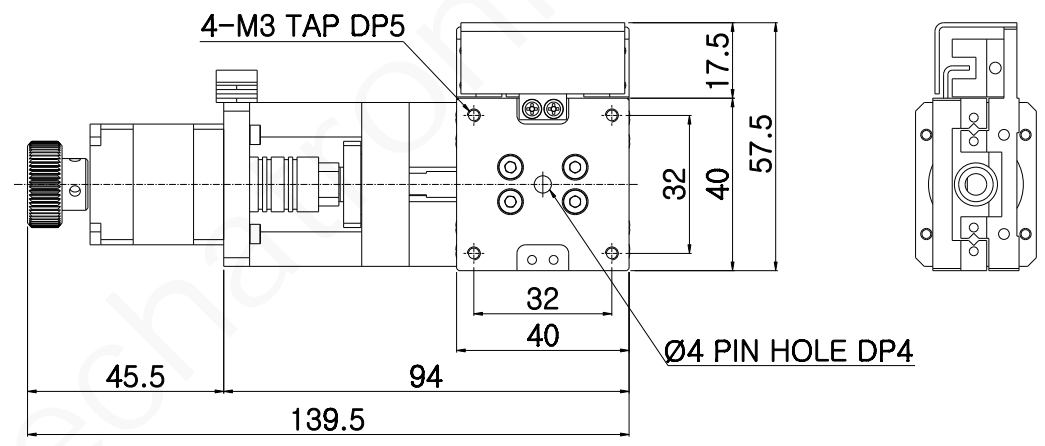
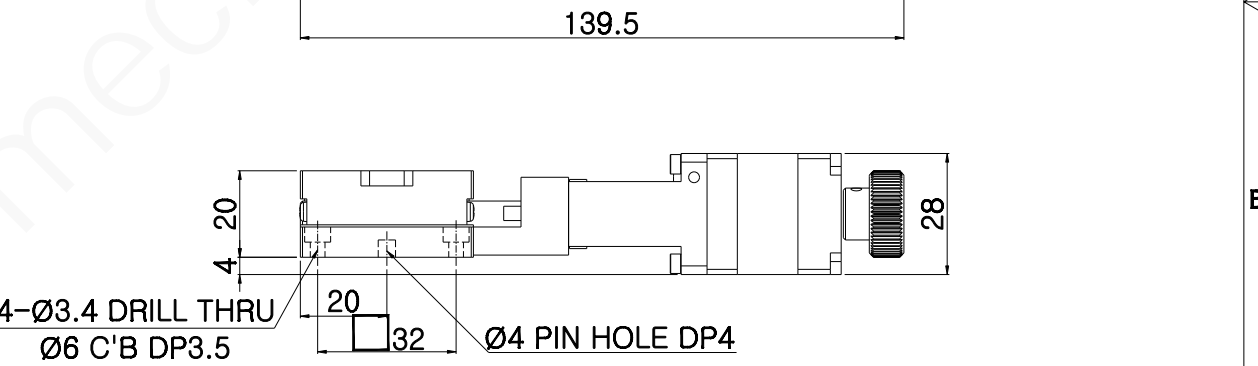
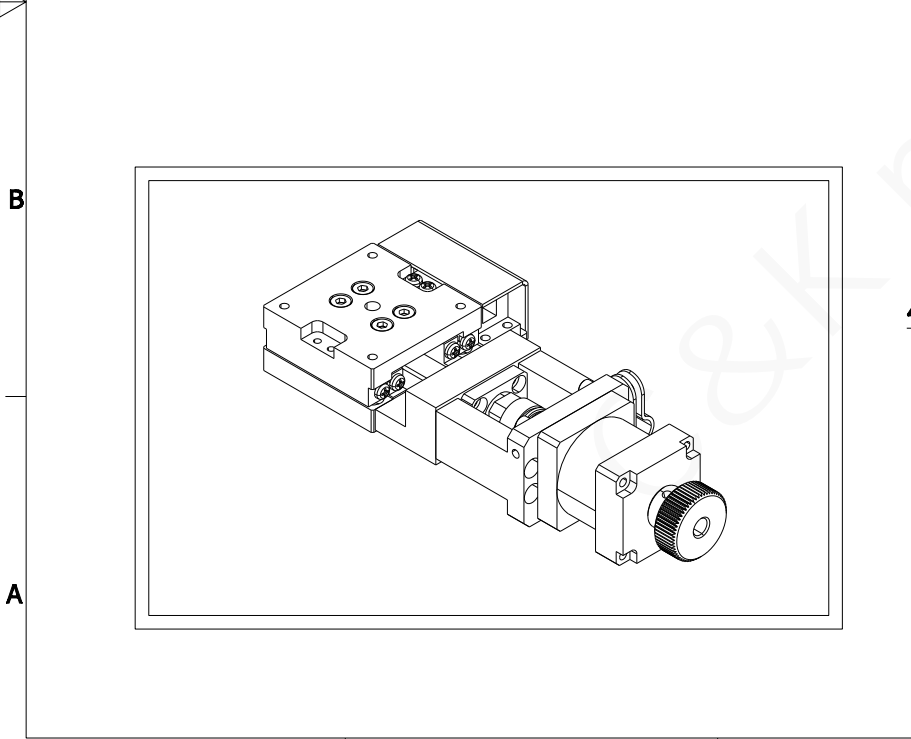
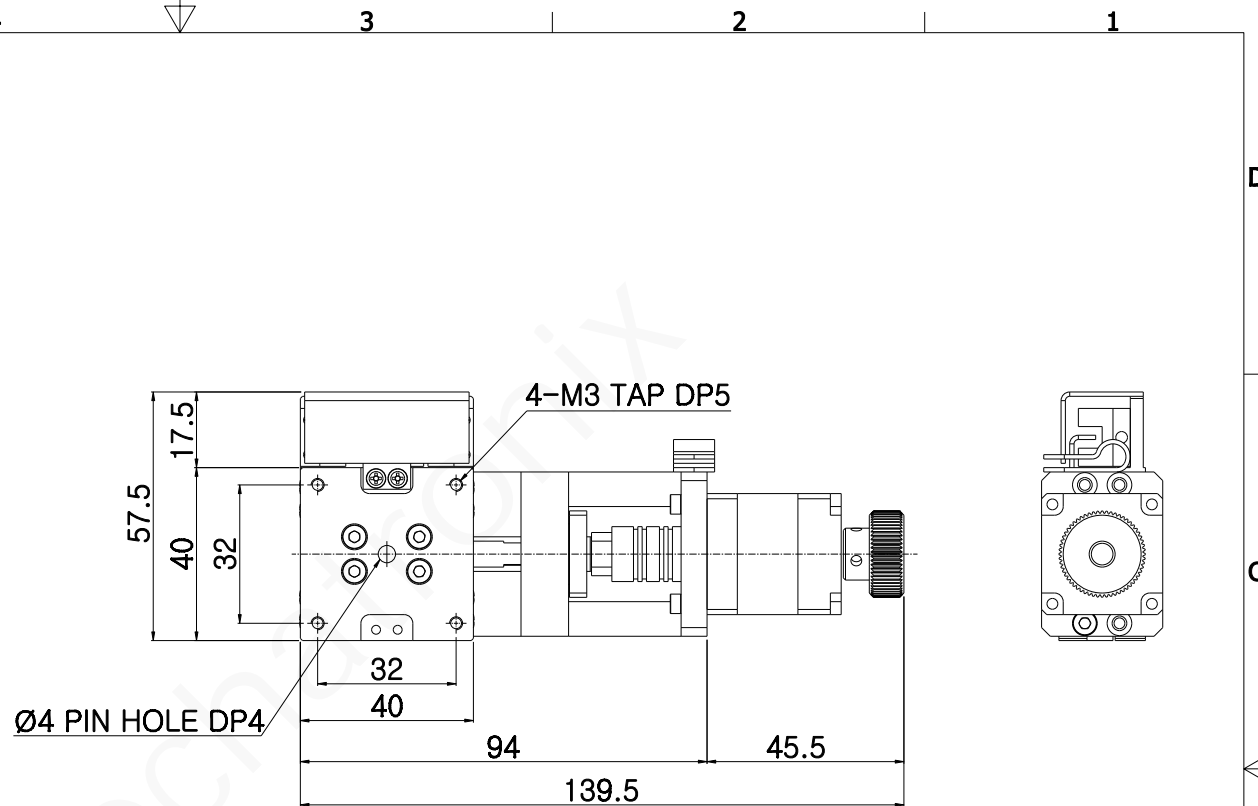

JMSX - 40R
 东莞市诚鲲五金电子科技有限公司
 sales01@dck-gd.com