

Email : sales01@dck-gd.com

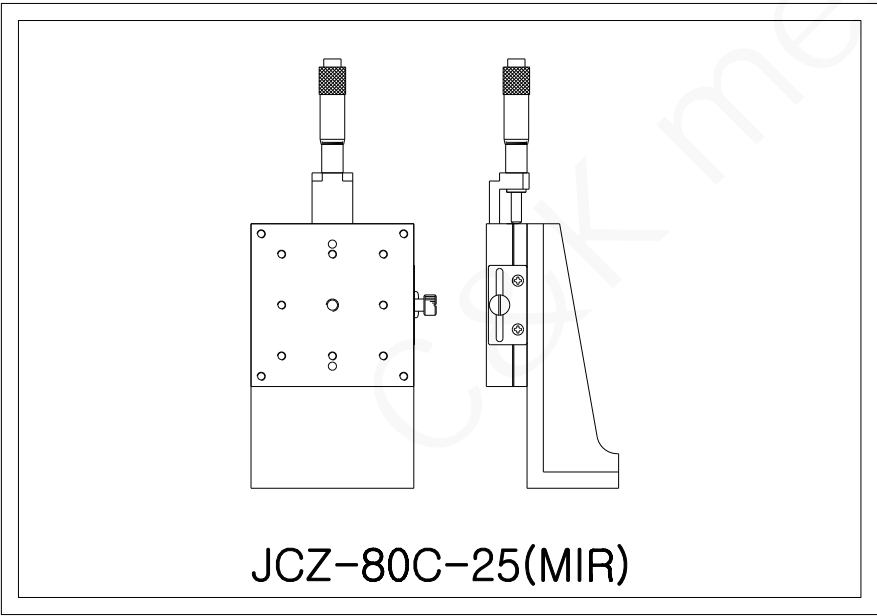
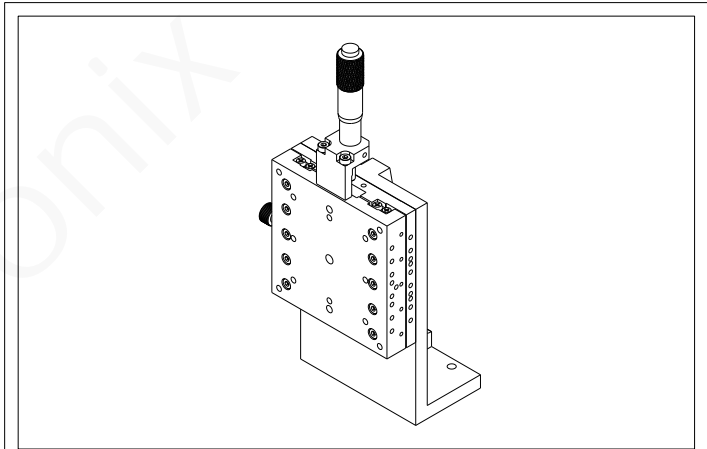
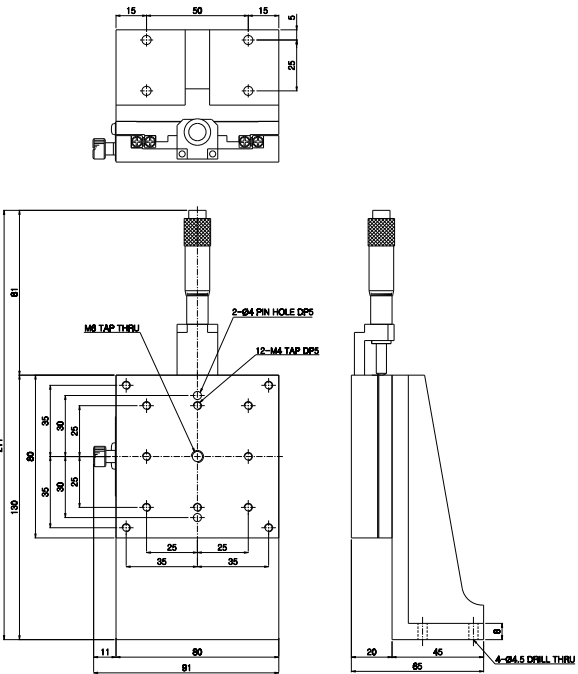

JCZ-80C-25(MIR)

Model	JCZ-80C-25
Surface Size	80x80mm
Position of Micrometer Head	Center
Travel Range	±12.5mm
Minimum Reading of Micrometer	10um
Guide Type	Crossed Roller Guide
Load Capacity	5Kgf
Parallelism	80um
Driving Parallelism	30um
Weight	0.69Kg
Material	Aluminum
Finish Treatment	Black Anodizing

JCZ - 80C - 25

Email : sales01@dck-gd.com

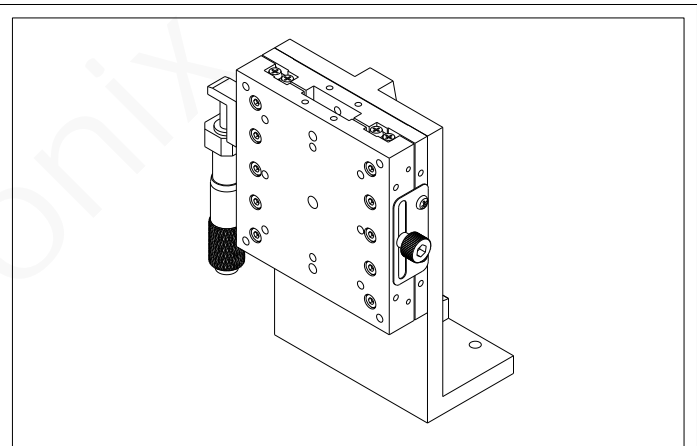
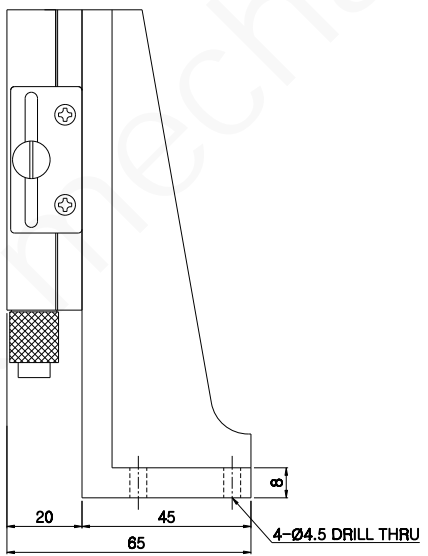
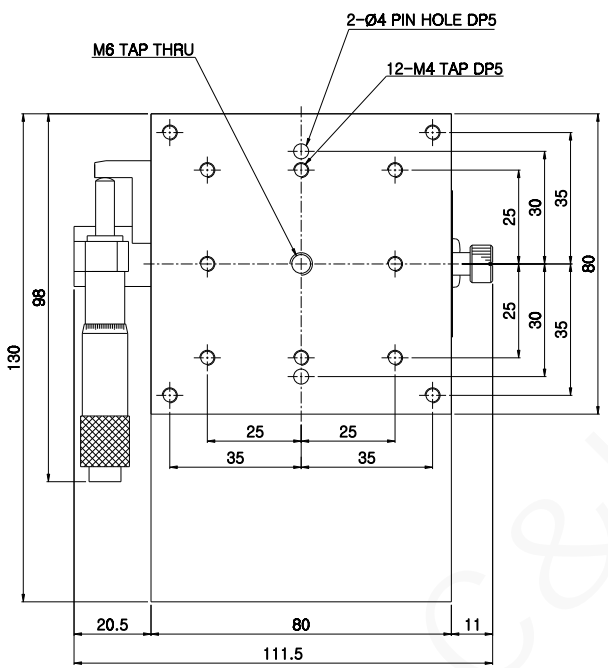
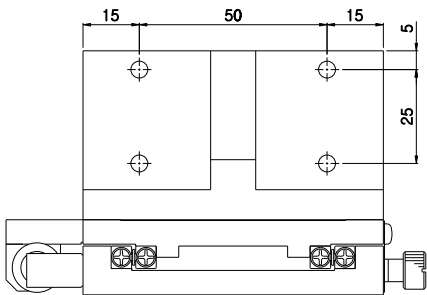

Model	JCZ-80L-25
Surface Size	80x80mm
Position of Micrometer Head	Left
Travel Range	±12.5mm
Minimum Reading of Micrometer	10um
Guide Type	Crossed Roller Guide
Load Capacity	5Kgf
Parallelism	80um
Driving Parallelism	30um
Weight	0.69Kg
Material	Aluminum
Finish Treatment	Black Anodizing

JCZ - 80L - 25
 东莞市诚鲲五金电子科技有限公司

Email : sales01@dck-gd.com

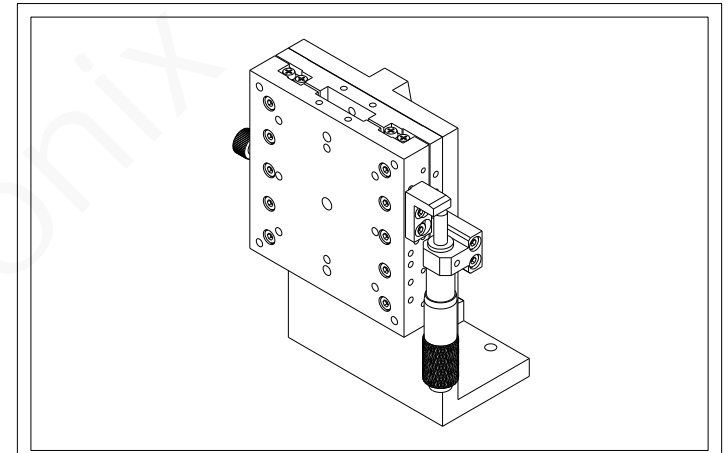
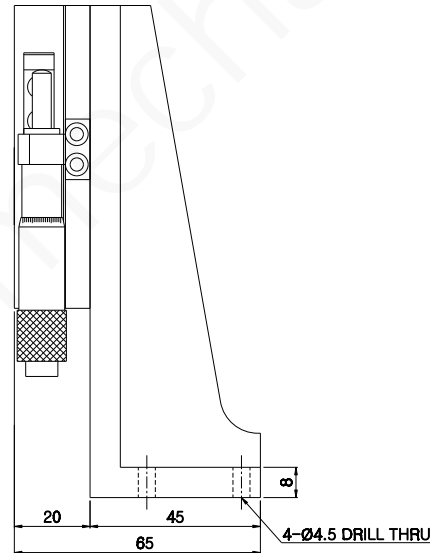
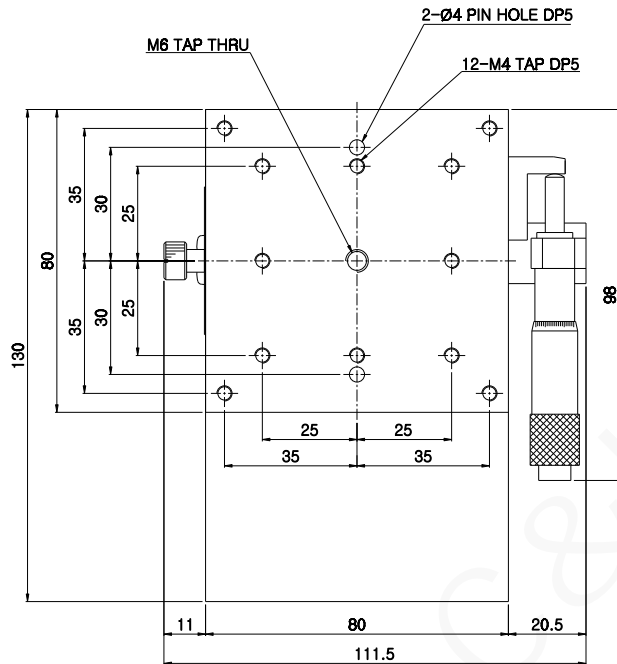
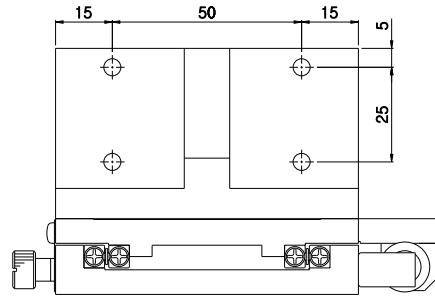

Model	JCZ-80R-25
Surface Size	80x80mm
Position of Micrometer Head	Right
Travel Range	±12.5mm
Minimum Reading of Micrometer	10um
Guide Type	Crossed Roller Guide
Load Capacity	5Kgf
Parallelism	80um
Driving Parallelism	30um
Weight	0.69Kg
Material	Aluminum
Finish Treatment	Black Anodizing

JCZ - 80R - 25

东莞市诚鲲五金电子科技有限公司