

Email:sales01@dck-gd.com

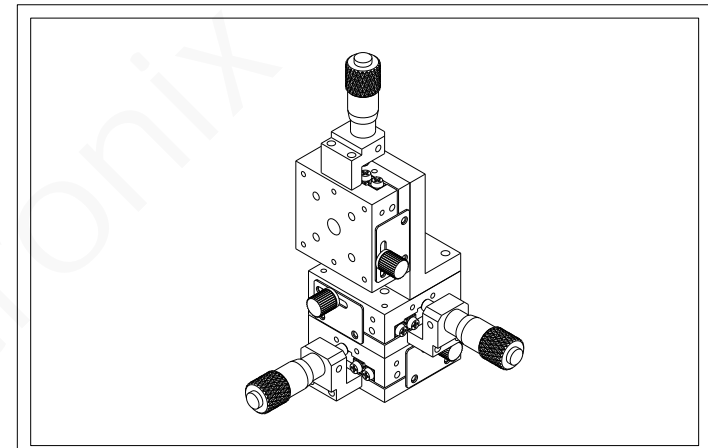

| | |
|-------------------------------|----------------------|
| Model | JCXYZ-30C |
| Surface Size | 30x30mm |
| Position of Micrometer Head | Center |
| Travel Range | ±3.25mm |
| Minimum Reading of Micrometer | 10um |
| Guide Type | Crossed Roller Guide |
| Load Capacity | 0.7Kgf |
| Parallelism | 80um |
| Driving Parallelism | 25um |
| Weight | 0.23Kg |
| Material | Aluminum |
| Finish Treatment | Black Anodizing |

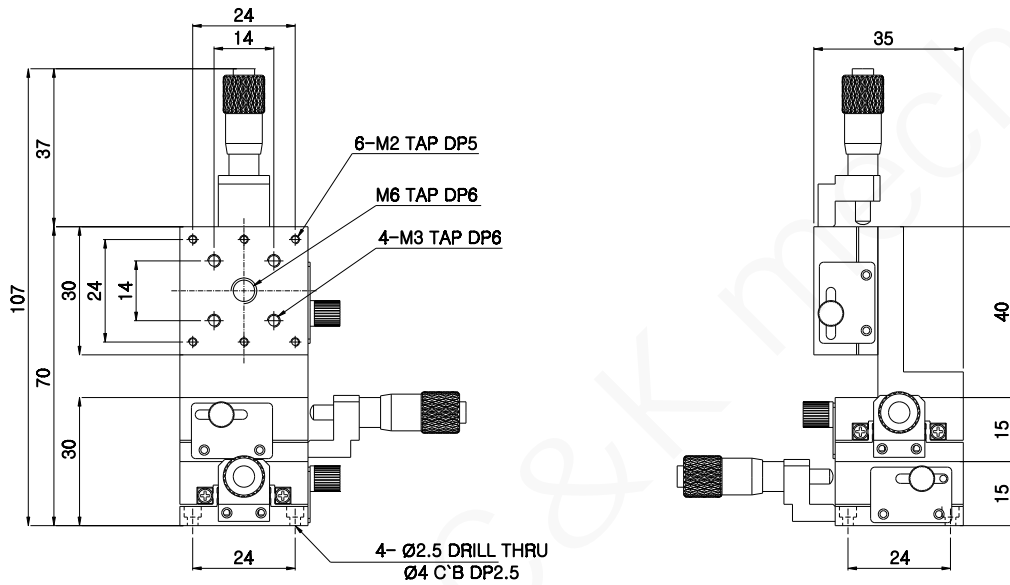
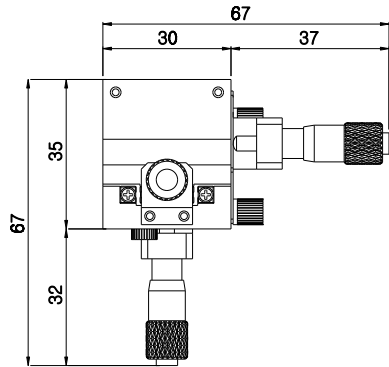

JCXYZ - 30C
 东莞市诚鯤五金电子科技有限公司
 sales01@dck-gd.com

Email:sales01@dck-gd.com

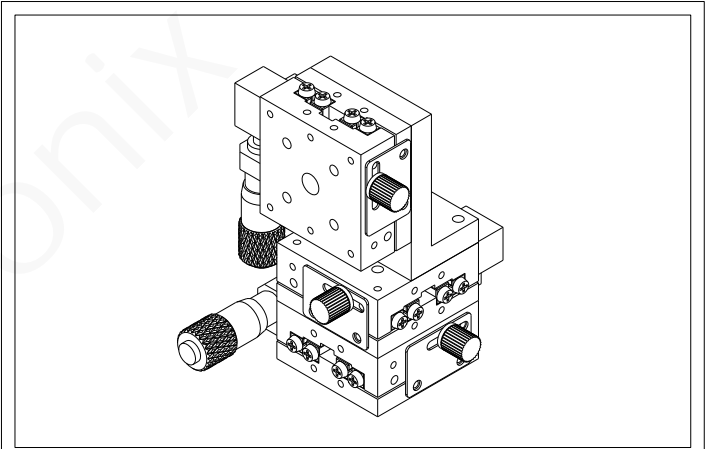

| | |
|-------------------------------|----------------------|
| Model | JCXYZ-30L |
| Surface Size | 30x30mm |
| Position of Micrometer Head | Center |
| Travel Range | ±3.25mm |
| Minimum Reading of Micrometer | 10um |
| Guide Type | Crossed Roller Guide |
| Load Capacity | 0.7Kgf |
| Parallelism | 80um |
| Driving Parallelism | 25um |
| Weight | 0.23Kg |
| Material | Aluminum |
| Finish Treatment | Black Anodizing |

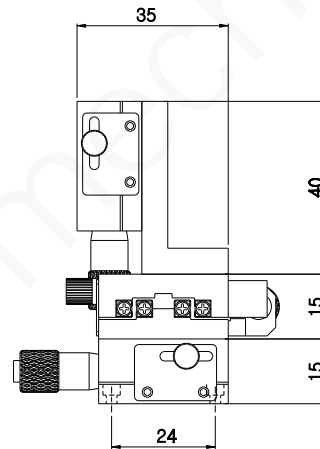
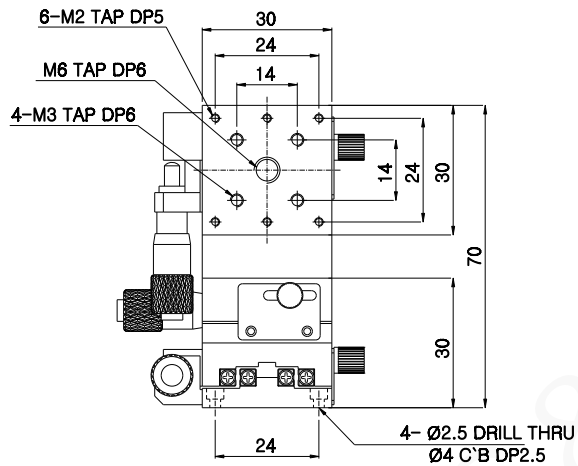
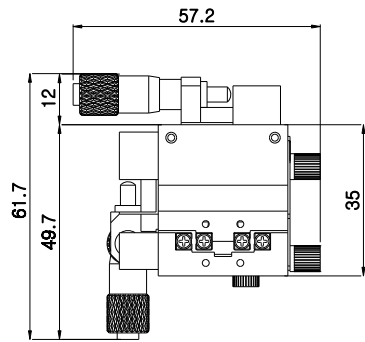

JCXYZ - 30L

东莞市诚颯五金电子科技有限公司
sales01@dck-gd.com

Email:sales01@dck-gd.com

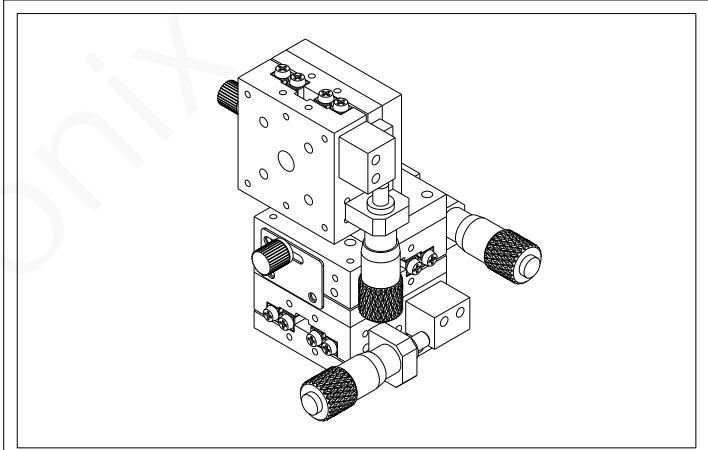

| | |
|-------------------------------|----------------------|
| Model | JCXYZ-30R |
| Surface Size | 30x30mm |
| Position of Micrometer Head | Center |
| Travel Range | ±3.25mm |
| Minimum Reading of Micrometer | 10um |
| Guide Type | Crossed Roller Guide |
| Load Capacity | 0.7Kgf |
| Parallelism | 80um |
| Driving Parallelism | 25um |
| Weight | 0.23Kg |
| Material | Aluminum |
| Finish Treatment | Black Anodizing |

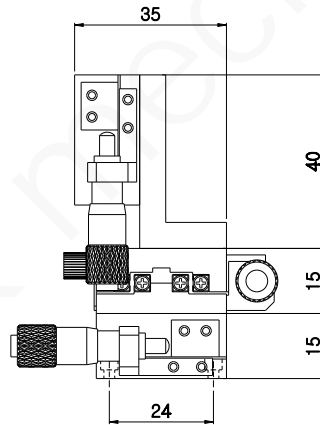
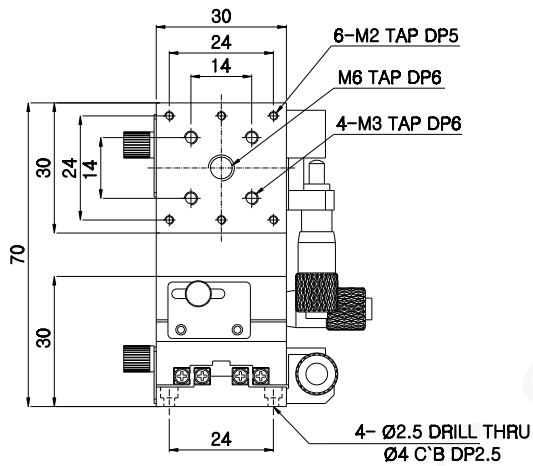
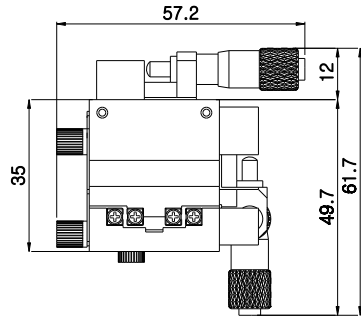

JCXYZ - 30R

东莞市诚錕五金电子科技有限公司
sales01@dck-gd.com