

Email : sales01@dck-gd.com

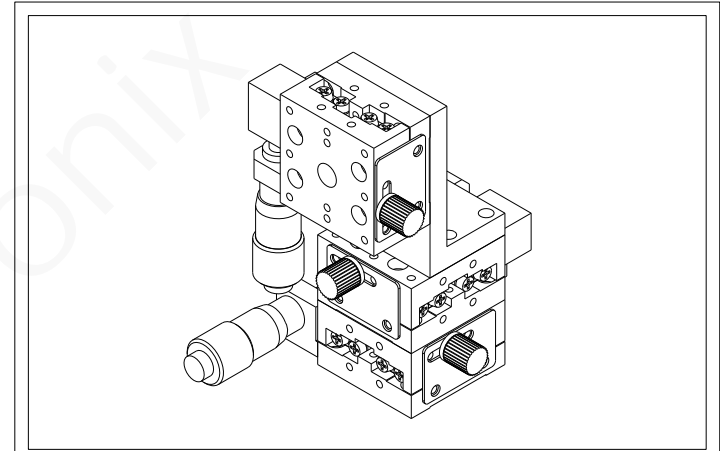
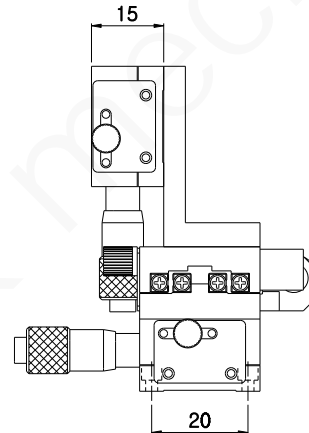
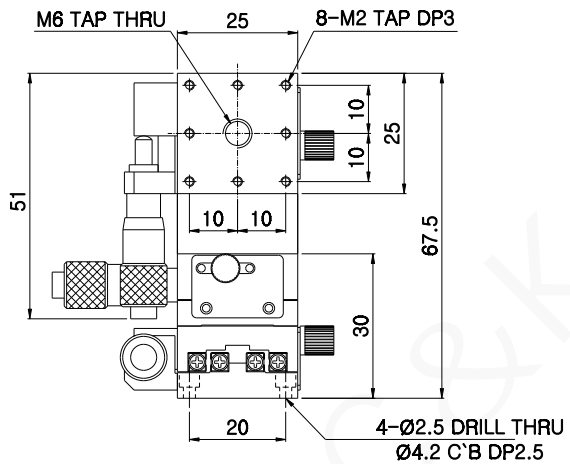
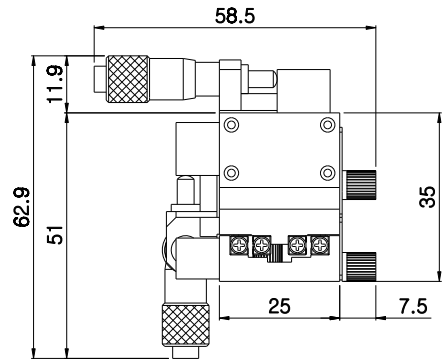

Model	JCXYZ-25L
Surface Size	25x25mm
Position of Micrometer Head	Left
Travel Range	±3.25mm
Minimum Reading of Micrometer	10um
Guide Type	Crossed Roller Guide
Load Capacity	0.5Kgf
Parallelism	80um
Driving Parallelism	25um
Weight	0.14Kg
Material	Aluminum
Finish Treatment	Black Anodizing

JCXYZ - 25L

东莞市诚鲲五金电子科技有限公司

Email : sales01@dck-gd.com

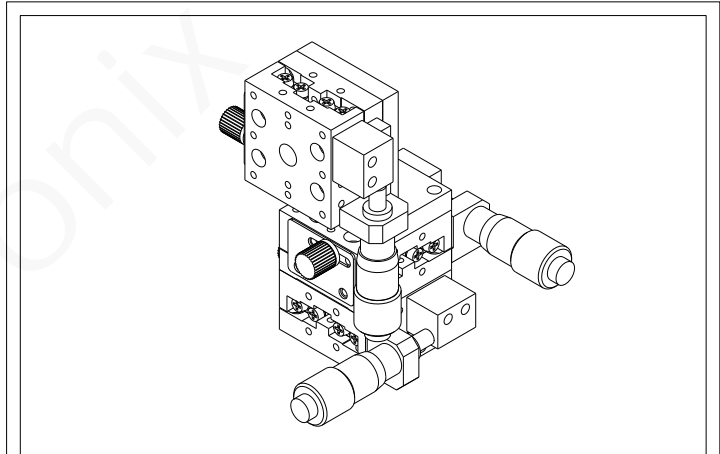
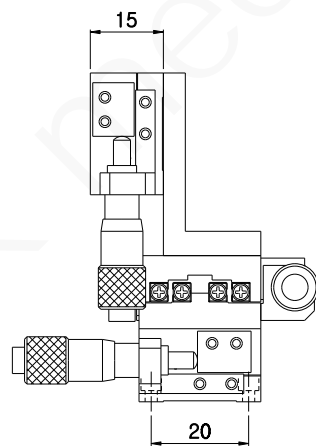
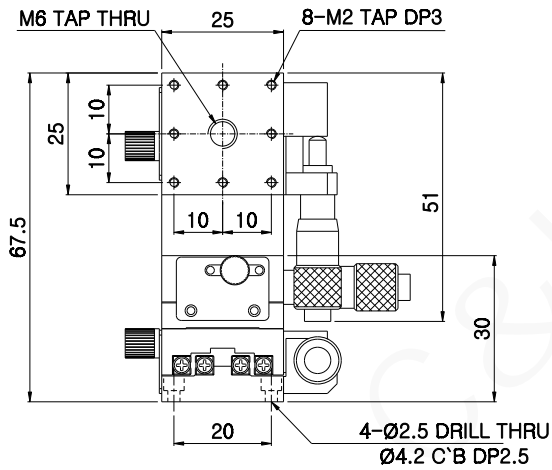
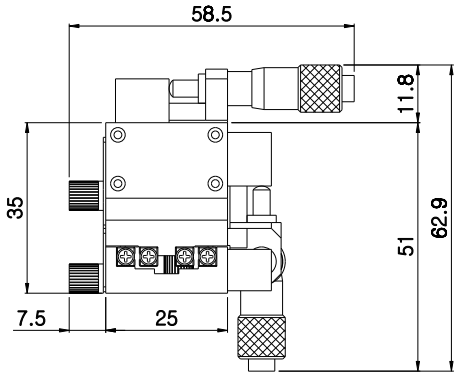

Model	JCXYZ-25R
Surface Size	25x25mm
Position of Micrometer Head	Right
Travel Range	±3.25mm
Minimum Reading of Micrometer	10um
Guide Type	Crossed Roller Guide
Load Capacity	0.5Kg
Parallelism	80um
Driving Parallelism	25um
Weight	0.14Kg
Material	Aluminum
Finish Treatment	Black Anodizing

JCXYZ - 25R
 东莞市诚鲲五金电子科技有限公司