

Email : sales01@dck-gd.com

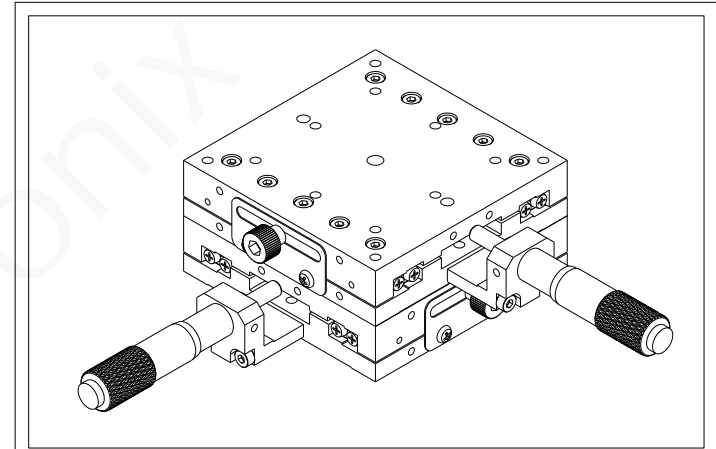
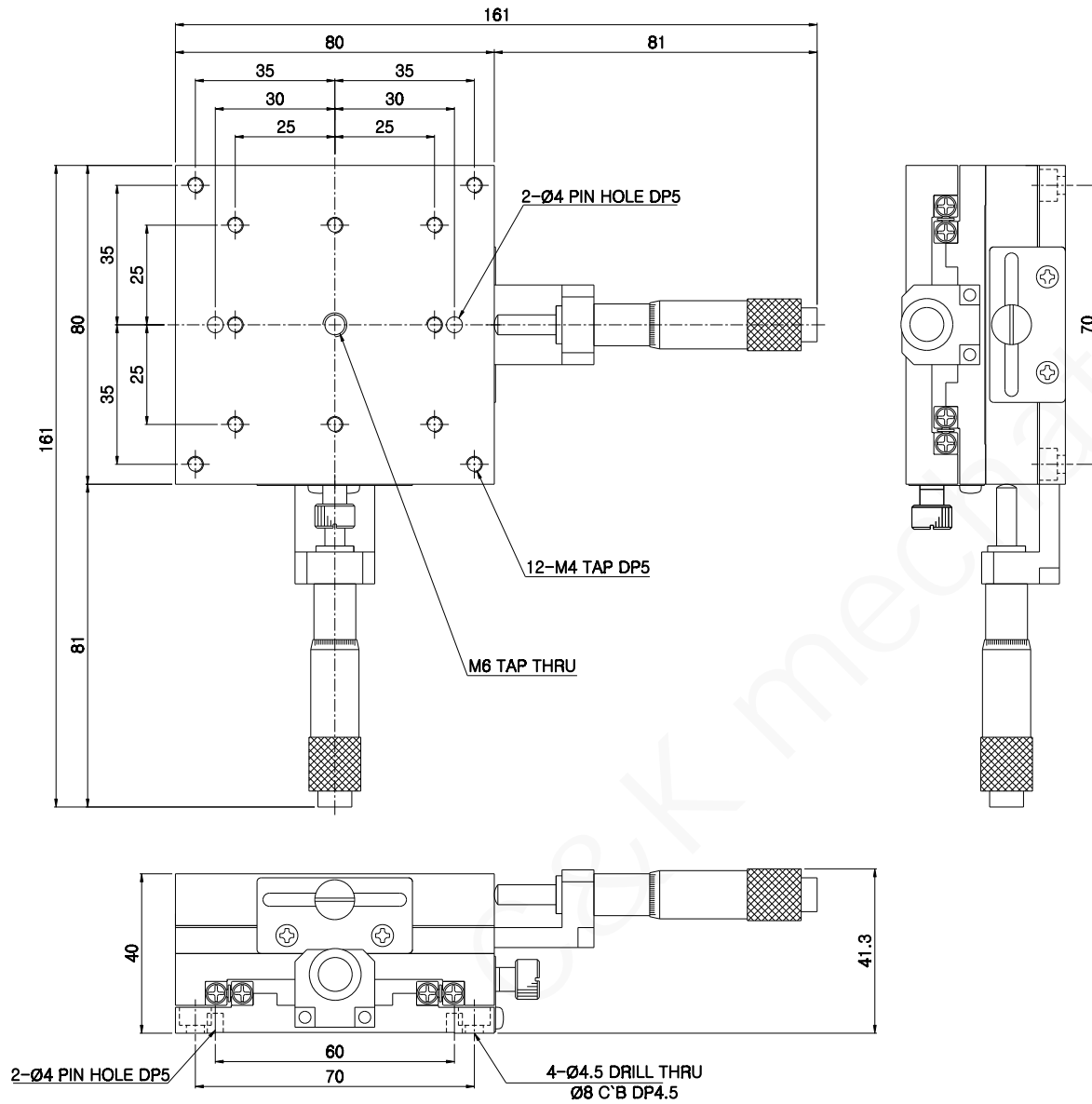

Model	JCXY-80C-25
Surface Size	80x80mm
Position of Micrometer Head	Center
Travel Range	±12.5mm
Minimum Reading of Micrometer	10um
Guide Type	Crossed Roller Guide
Load Capacity	9.5Kgf
Parallelism	60um
Driving Parallelism	20um
Weight	0.82Kg
Material	Aluminum
Finish Treatment	Black Anodizing

JCXY - 80C - 25

Email : sales01@dck-gd.com

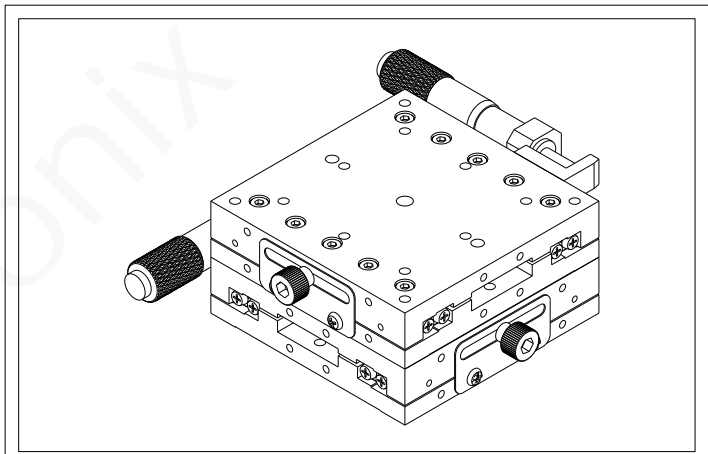
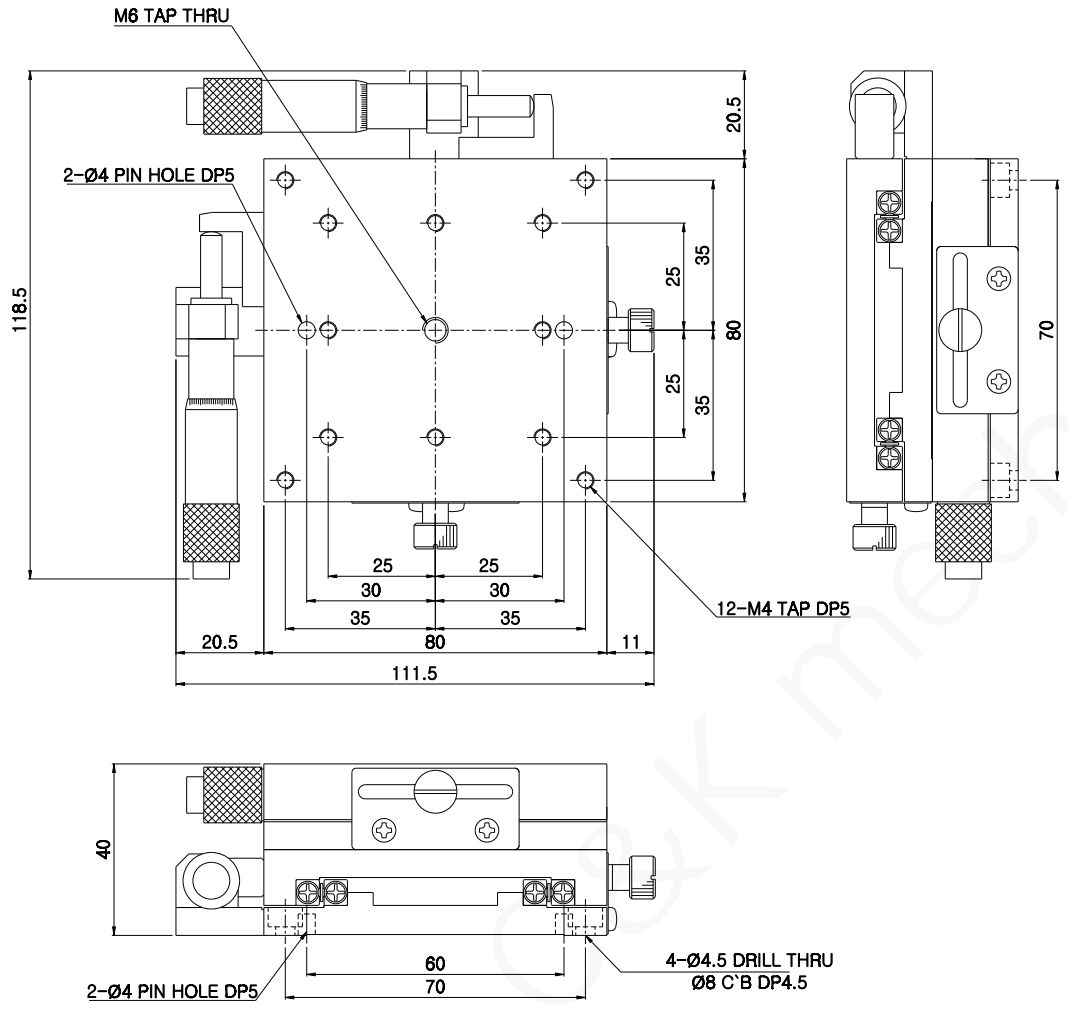

Model	JCXY-80L-25
Surface Size	80x80mm
Position of Micrometer Head	Left
Travel Range	±12.5mm
Minimum Reading of Micrometer	10um
Guide Type	Crossed Roller Guide
Load Capacity	9.5Kgf
Parallelism	60um
Driving Parallelism	20um
Weight	0.82Kg
Material	Aluminum
Finish Treatment	Black Anodizing

JCXY - 80L - 25

东莞市诚鲲五金电子科技有限公司

Email : sales01@dck-gd.com

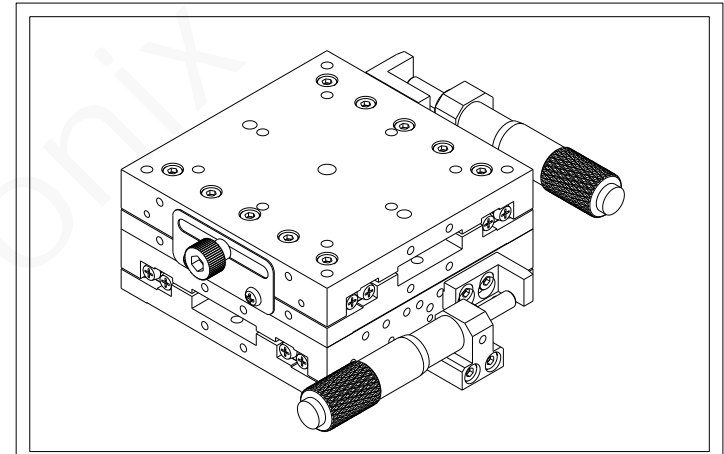
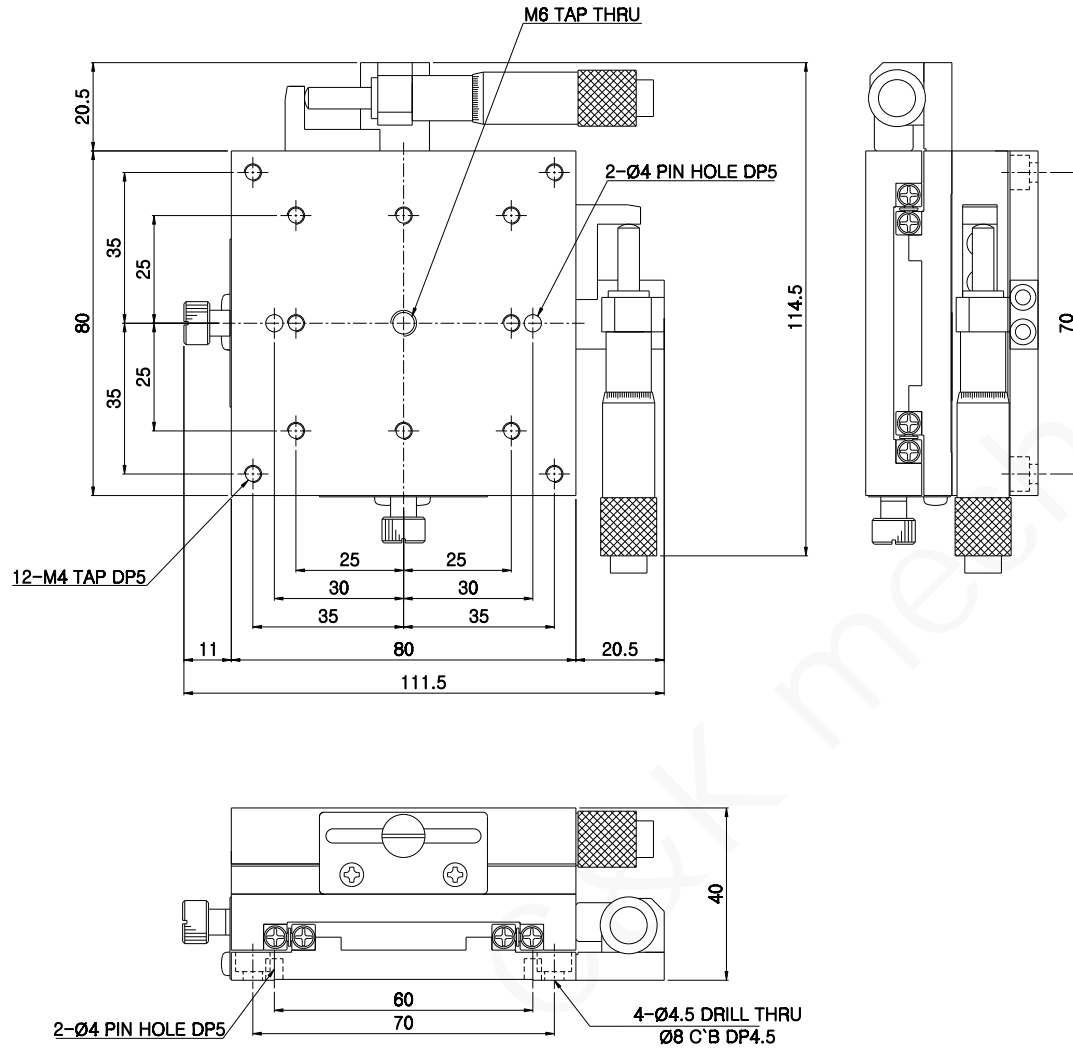

Model	JCXY-80R-25
Surface Size	80x80mm
Position of Micrometer Head	Right
Travel Range	±12.5mm
Minimum Reading of Micrometer	10um
Guide Type	Crossed Roller Guide
Load Capacity	9.5Kgf
Parallelism	60um
Driving Parallelism	20um
Weight	0.82Kg
Material	Aluminum
Finish Treatment	Black Anodizing

JCXY - 80R - 25

东莞市诚鲲五金电子科技有限公司