

Email:sales01@dck-gd.com

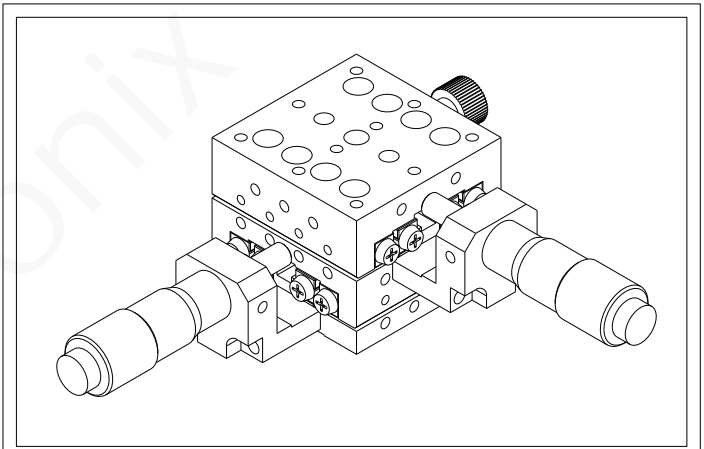

Model	JCXY-40CS
Surface Size	40x40mm
Position of Micrometer Head	Center
Travel Range	±6.5mm
Minimum Reading of Micrometer	10um
Guide Type	Crossed Roller Guide
Load Capacity	2.8Kgf
Parallelism	60um
Driving Parallelism	20um
Weight	0.20Kg
Material	Aluminum
Finish Treatment	Black Anodizing

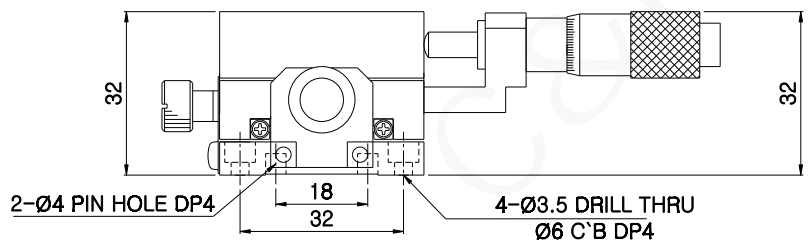
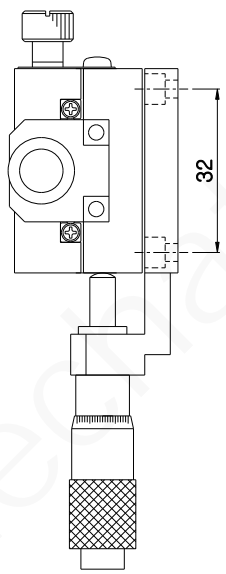
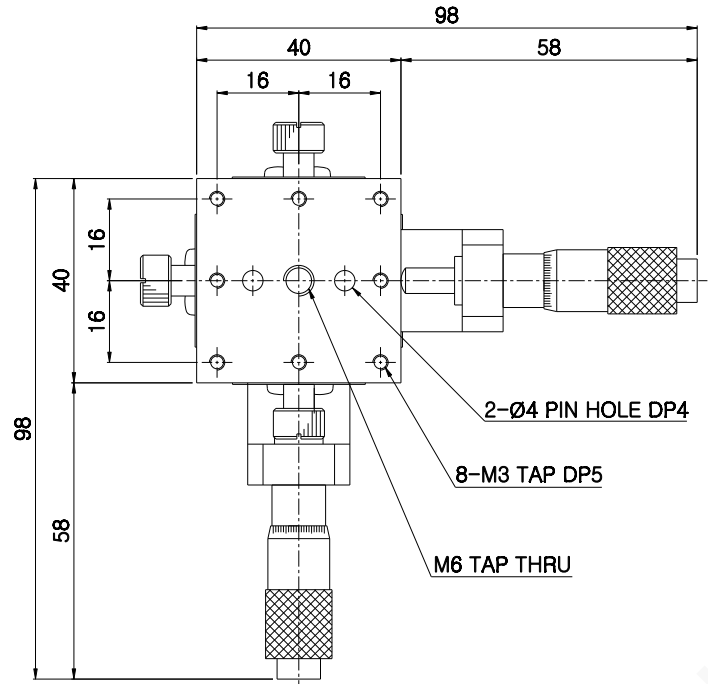

JCXY - 40CS

东莞市诚鲲五金电子科技有限公司

Email:sales01@dck-gd.com

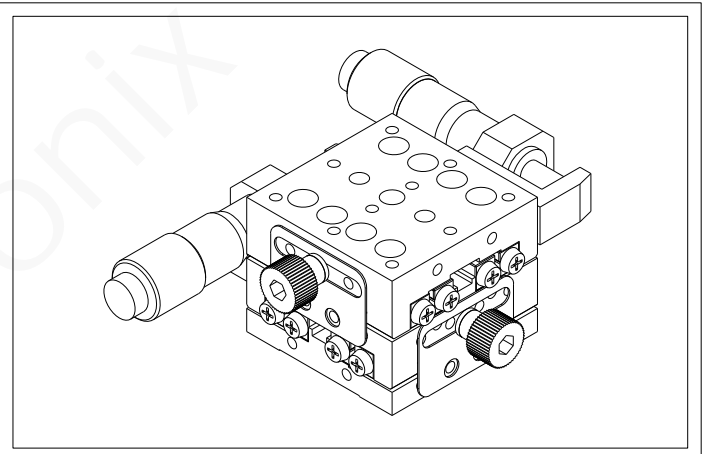

Model	JCXY-40LS
Surface Size	40x40mm
Position of Micrometer Head	Left
Travel Range	±6.5mm
Minimum Reading of Micrometer	10um
Guide Type	Crossed Roller Guide
Load Capacity	2.8Kgf
Parallelism	60um
Driving Parallelism	20um
Weight	0.22Kg
Material	Aluminum
Finish Treatment	Black Anodizing

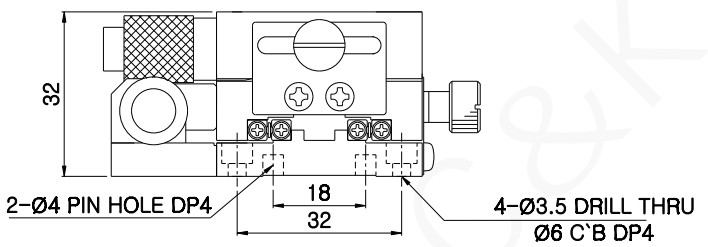
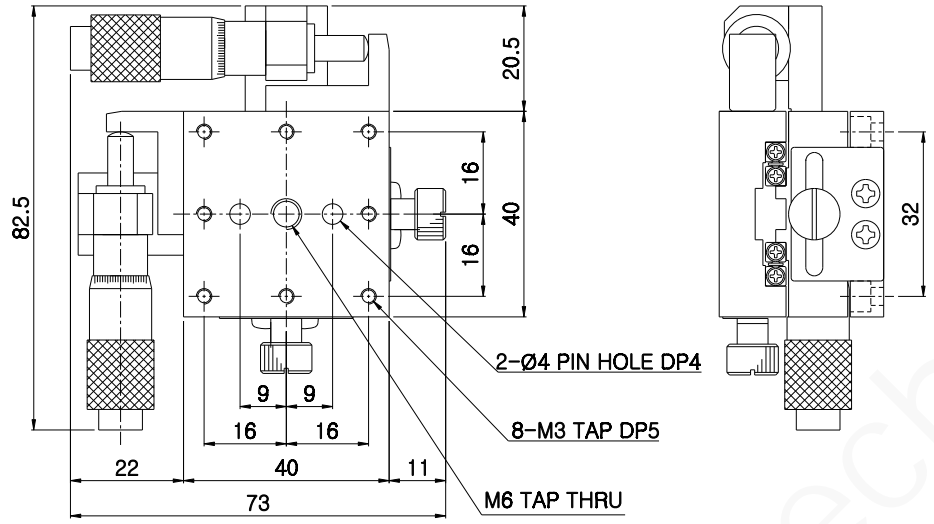

JCXY - 40LS

东莞市诚颯五金电子科技有限公司

Email:sales01@dck-gd.com

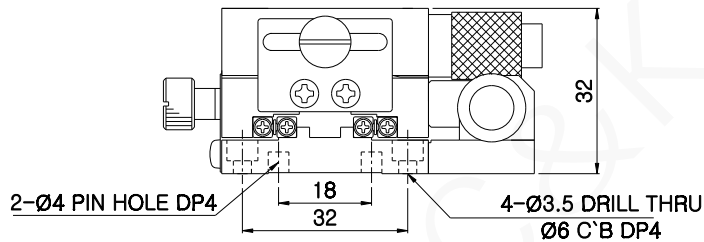
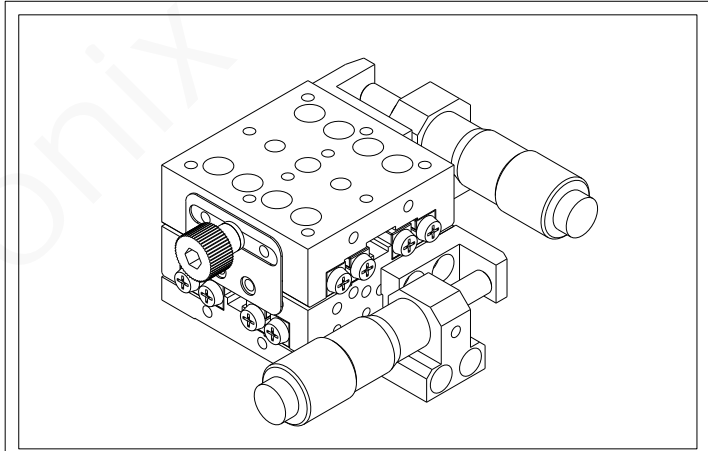
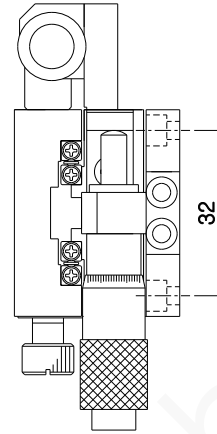
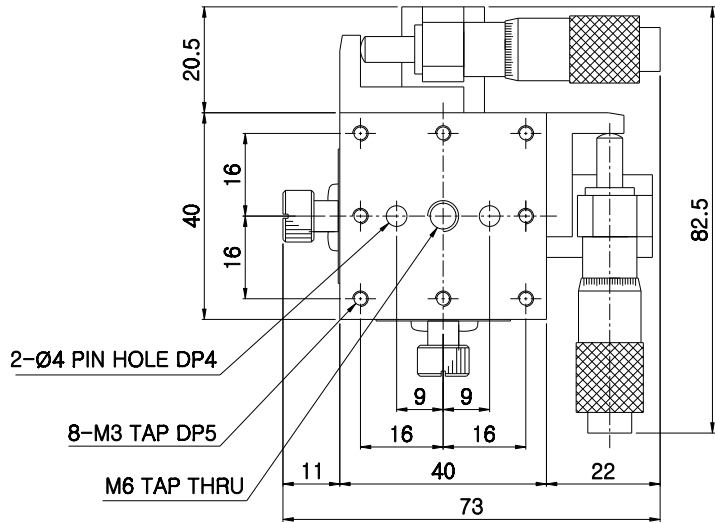

Model	JCXY-40RS
Surface Size	40x40mm
Position of Micrometer Head	Right
Travel Range	±6.5mm
Minimum Reading of Micrometer	10um
Guide Type	Crossed Roller Guide
Load Capacity	2.8Kgf
Parallelism	60um
Driving Parallelism	20um
Weight	0.22Kg
Material	Aluminum
Finish Treatment	Black Anodizing

JCXY - 40RS

东莞市诚鲲五金电子科技有限公司