

Email:sales01@dck-gd.com

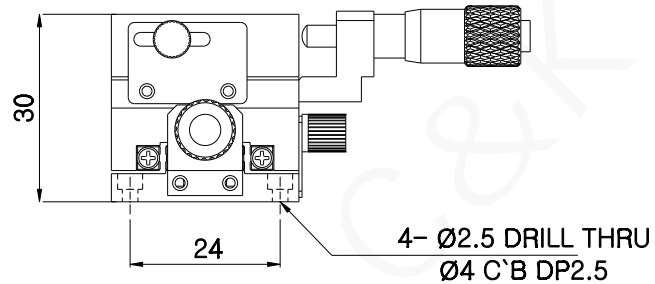
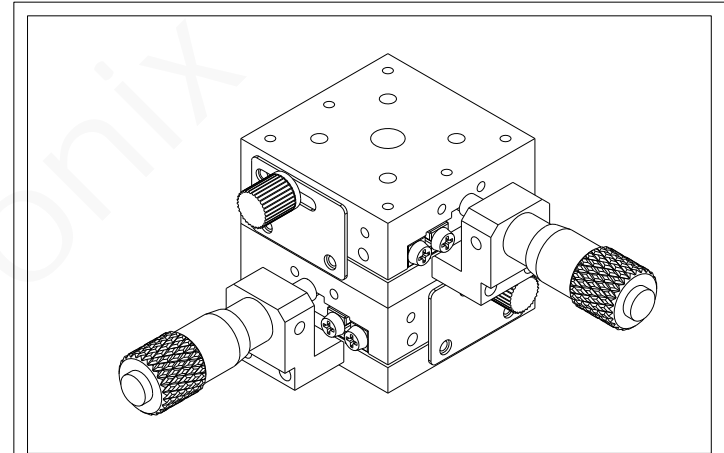
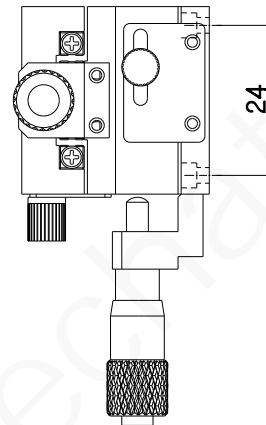
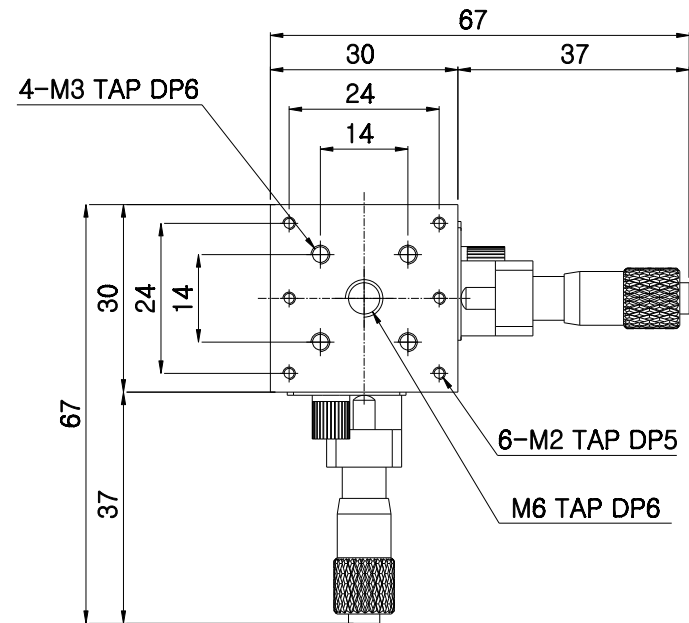

Model	JCXY-30C
Surface Size	30x30mm
Position of Micrometer Head	Center
Travel Range	±3.25mm
Minimum Reading of Micrometer	10um
Guide Type	Crossed Roller Guide
Load Capacity	1Kgf
Parallelism	60um
Driving Parallelism	20um
Weight	0.14Kg
Material	Aluminum
Finish Treatment	Black Anodizing

JCXY - 30C

东莞市诚鲲五金电子科技有限公司
Email:sales01@dck-gd.com

Email:sales01@dck-gd.com

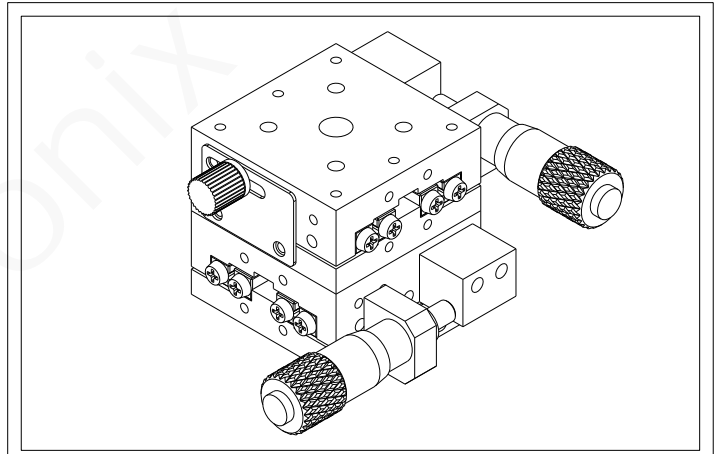
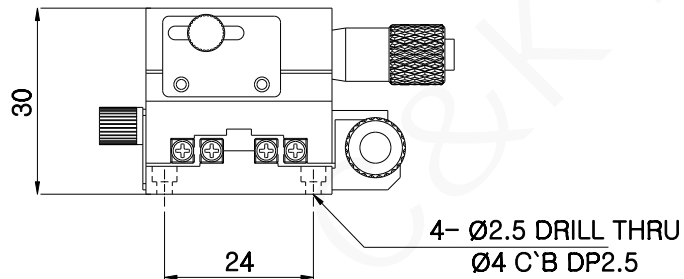
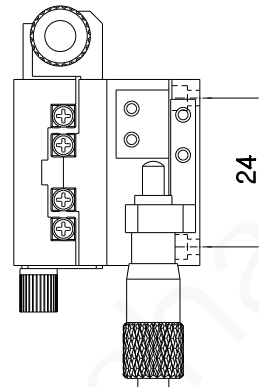
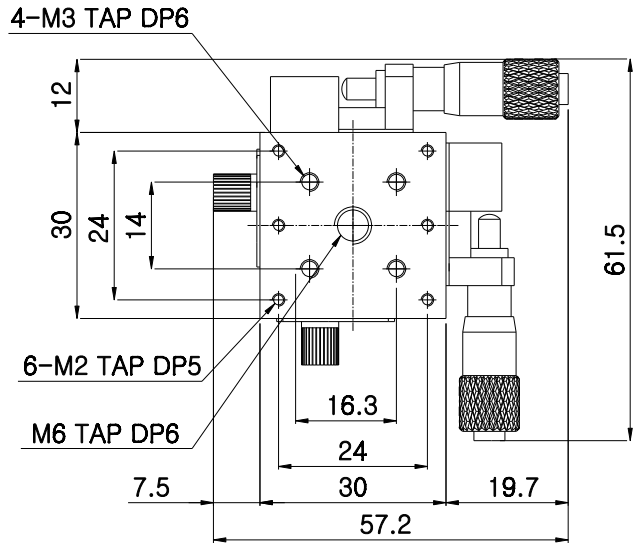

Model	JCXY-30R
Surface Size	30x30mm
Position of Micrometer Head	Center
Travel Range	±3.25mm
Minimum Reading of Micrometer	10um
Guide Type	Crossed Roller Guide
Load Capacity	1Kgf
Parallelism	60um
Driving Parallelism	20um
Weight	0.14Kg
Material	Aluminum
Finish Treatment	Black Anodizing

JCXY - 30R

东莞市诚鲲五金电子科技有限公司
Email:sales01@dck-gd.com