

Email : sales01@dck-gd.com

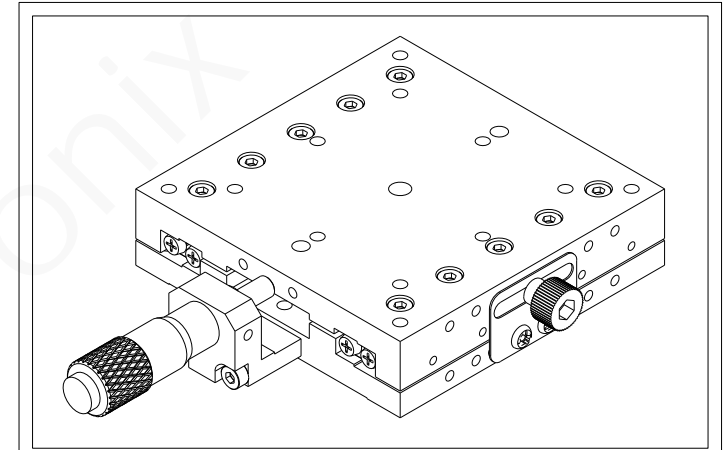
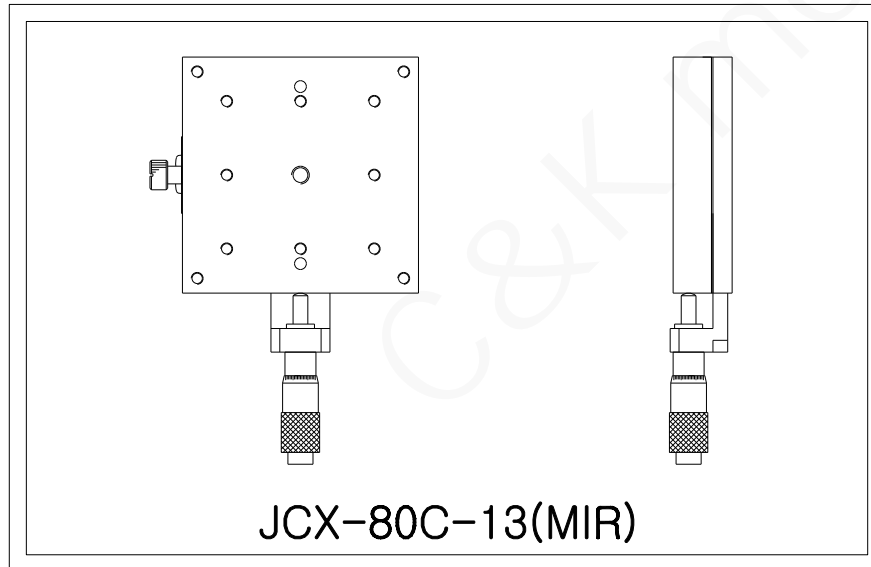
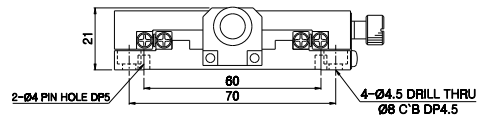
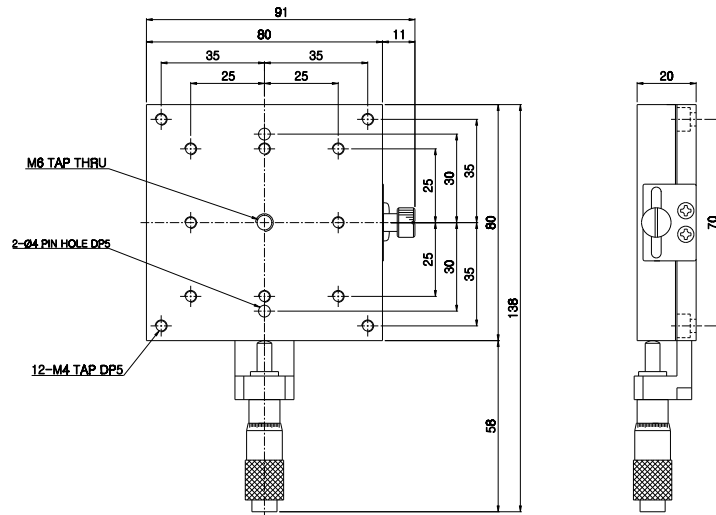

Model	JCX-80C-13
Surface Size	80x80mm
Position of Micrometer Head	Center
Travel Range	±6.5mm
Minimum Reading of Micrometer	10um
Guide Type	Crossed Roller Guide
Load Capacity	10Kgf
Parallelism	30um
Driving Parallelism	10um
Weight	0.39Kg
Material	Aluminum
Finish Treatment	Black Anodizing

JCX - 80C - 13

东莞市诚麒五金电子科技有限公司

Email : sales01@dck-gd.com

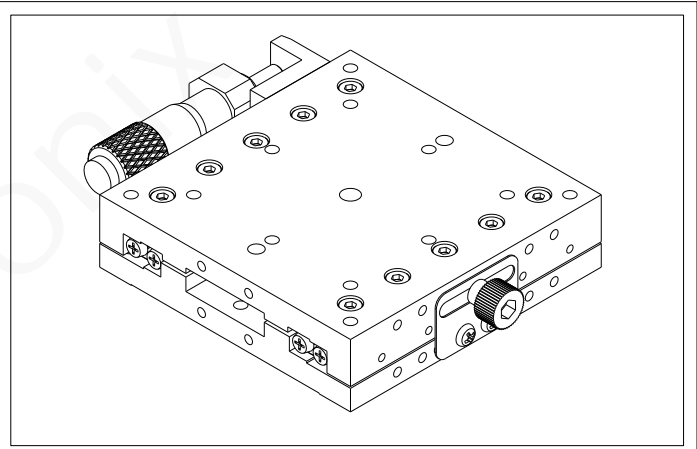
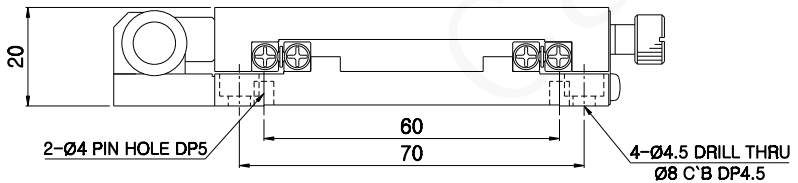
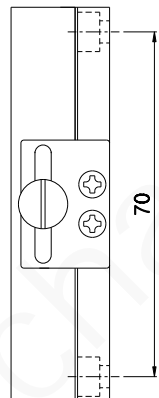
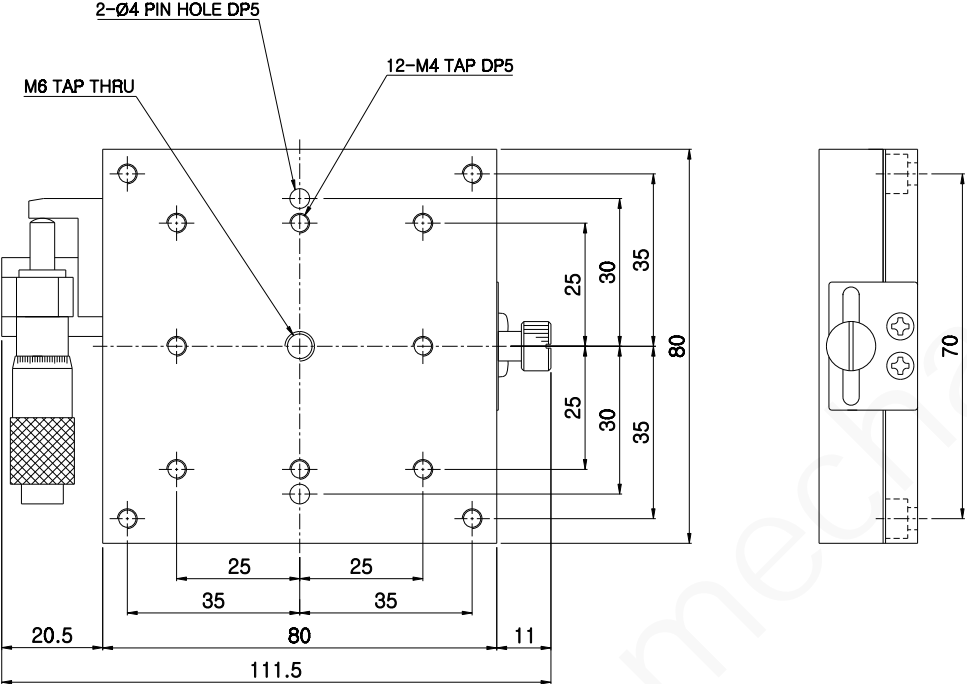

Model	JCX-80L-13
Surface Size	80x80mm
Position of Micrometer Head	Left
Travel Range	±6.5mm
Minimum Reading of Micrometer	10um
Guide Type	Crossed Roller Guide
Load Capacity	10Kgf
Parallelism	30um
Driving Parallelism	10um
Weight	0.40Kg
Material	Aluminum
Finish Treatment	Black Anodizing

JCX - 80L - 13

东莞市诚鲲五金电子科技有限公司

Email : sales01@dck-gd.com

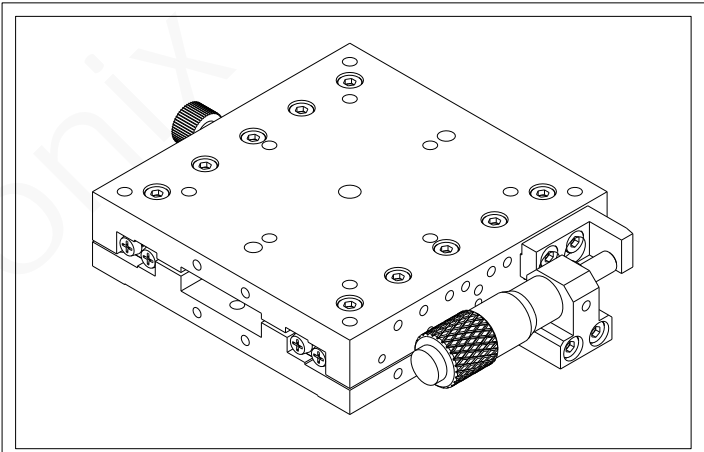
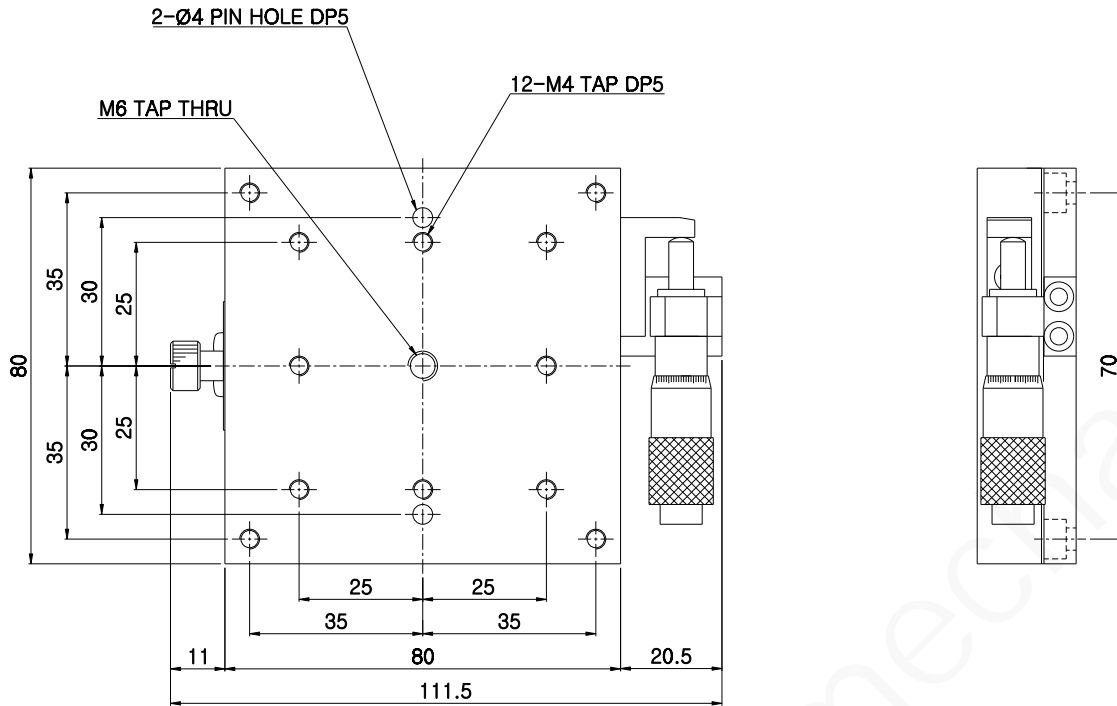

Model	JCX-80R-13
Surface Size	80x80mm
Position of Micrometer Head	Right
Travel Range	±6.5mm
Minimum Reading of Micrometer	10um
Guide Type	Crossed Roller Guide
Load Capacity	10Kgf
Parallelism	30um
Driving Parallelism	10um
Weight	0.40Kg
Material	Aluminum
Finish Treatment	Black Anodizing

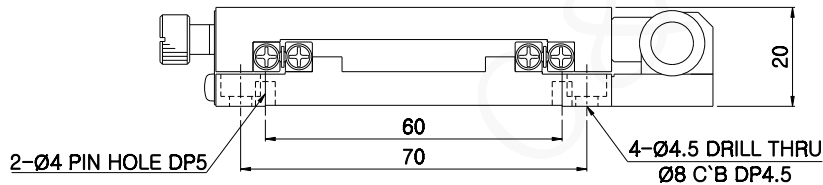

JCX - 80R - 13

东莞市诚鲲五金电子科技有限公司

Email : sales01@dck-gd.com

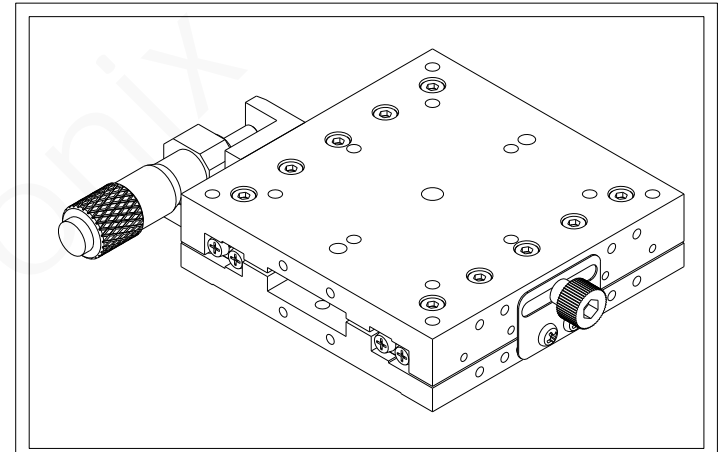
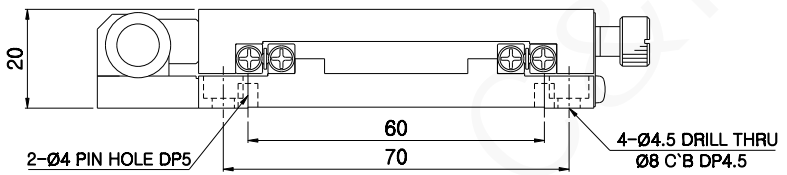
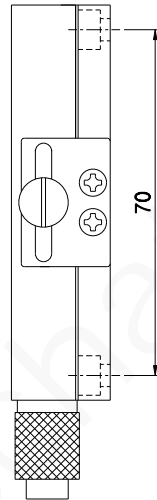
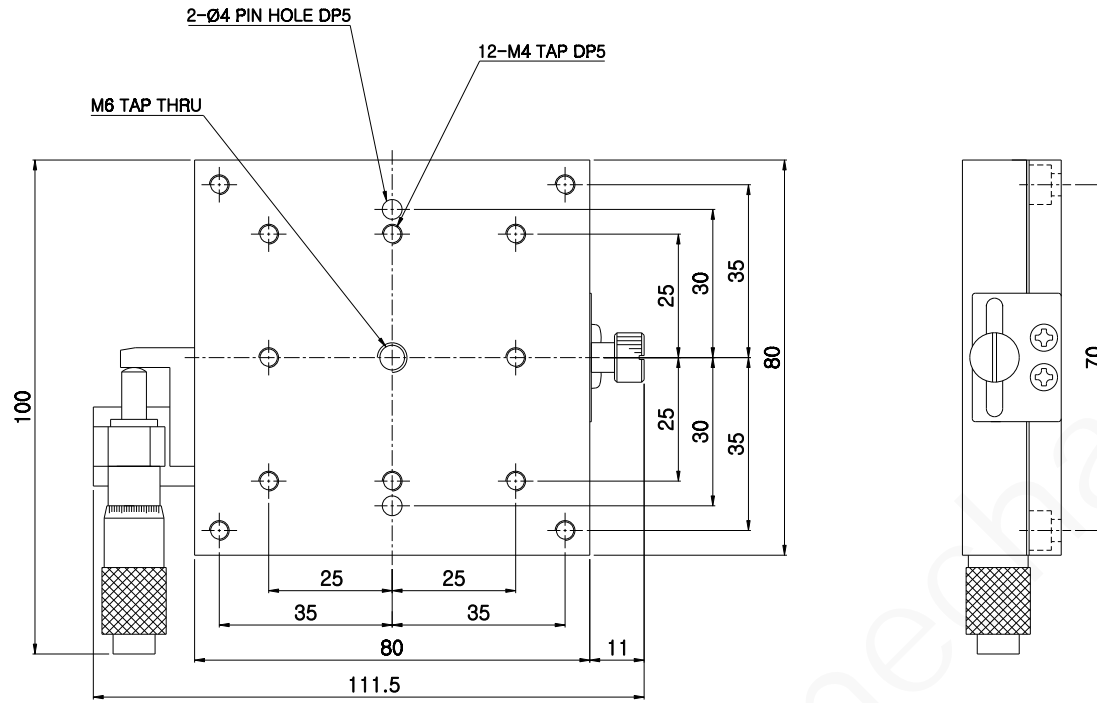

Model	JCX-80L-13-A
Surface Size	80x80mm
Position of Micrometer Head	Left
Travel Range	±6.5mm
Minimum Reading of Micrometer	10um
Guide Type	Crossed Roller Guide
Load Capacity	10Kgf
Parallelism	30um
Driving Parallelism	10um
Weight	0.40Kg
Material	Aluminum
Finish Treatment	Black Anodizing

JCX - 80L - 13 - A

东莞市诚鲲五金电子科技有限公司

Email : sales01@dck-gd.com

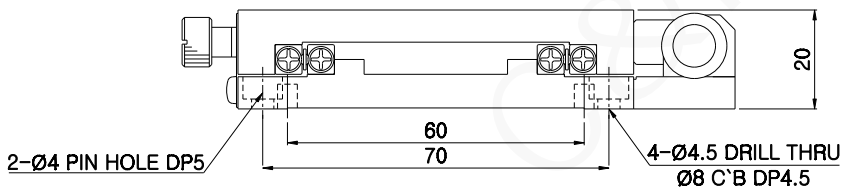
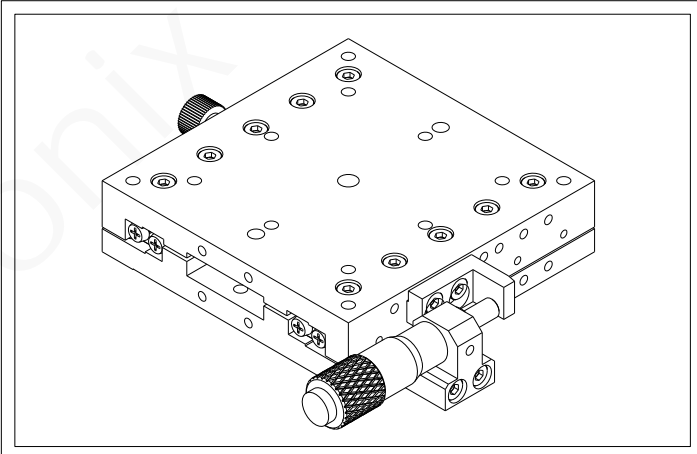
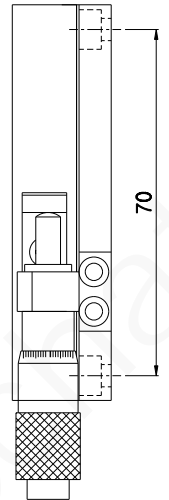
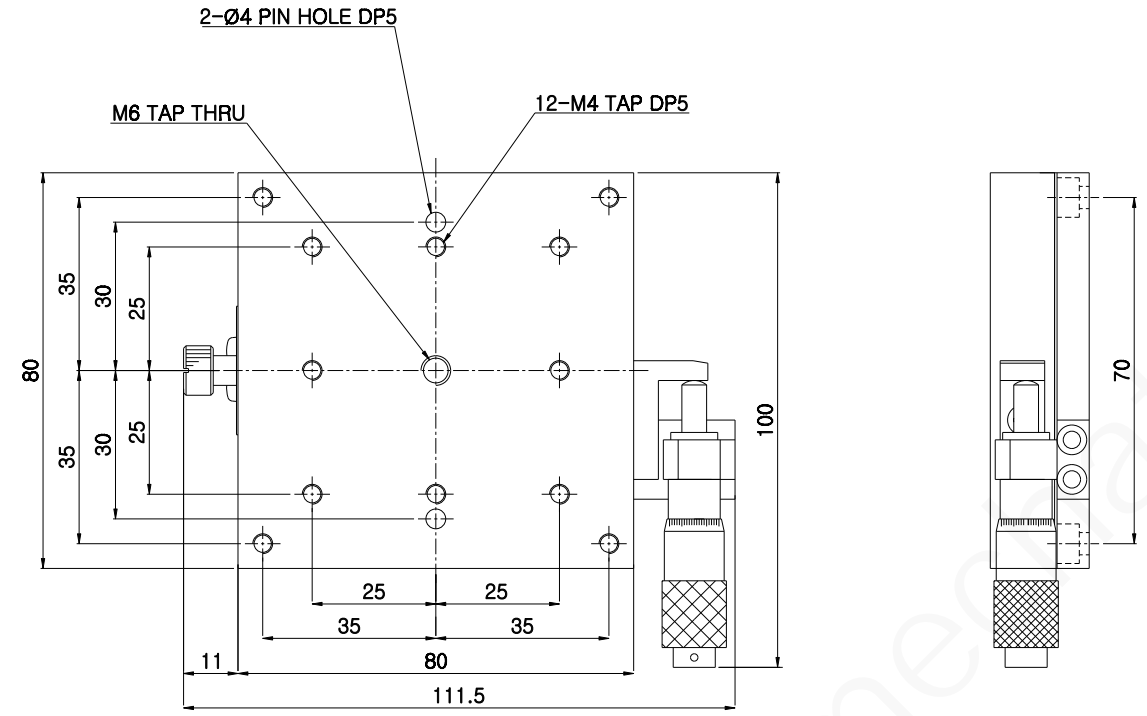

Model	JCX-80R-13-A
Surface Size	80x80mm
Position of Micrometer Head	Right
Travel Range	±6.5mm
Minimum Reading of Micrometer	10um
Guide Type	Crossed Roller Guide
Load Capacity	10Kgf
Parallelism	30um
Driving Parallelism	10um
Weight	0.40Kg
Material	Aluminum
Finish Treatment	Black Anodizing

JCX - 80R - 13 - A

东莞市诚鲲五金电子科技有限公司