

Email : sales01@dck-gd.com

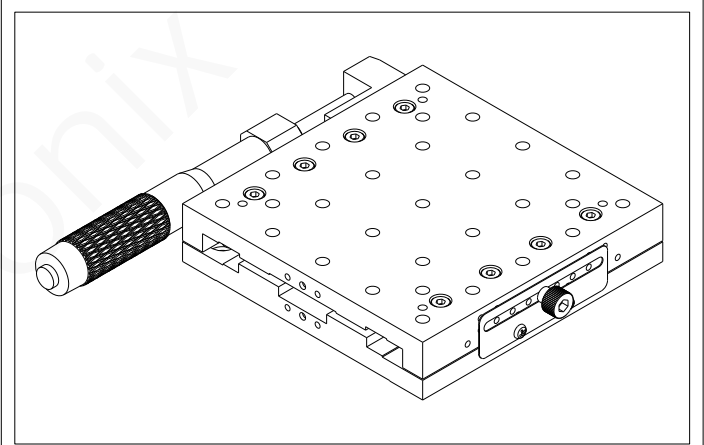
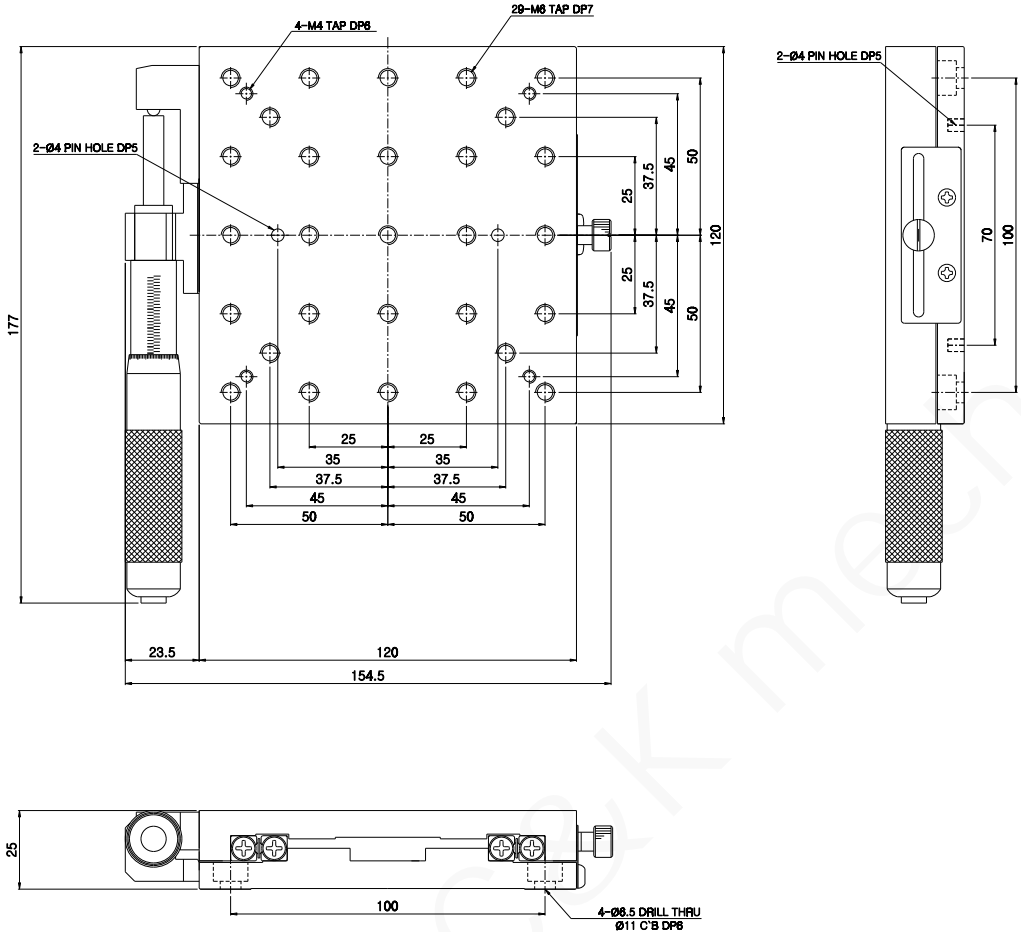

Model	JCX-120L-50
Surface Size	120x120mm
Position of Micrometer Head	Left
Travel Range	±25mm
Minimum Reading of Micrometer	10um
Guide Type	Crossed Roller Guide
Load Capacity	20Kgf
Parallelism	60um
Driving Parallelism	20um
Weight	1.5Kg
Material	Aluminum
Finish Treatment	Black Anodizing

JCX - 120L - 50
 东莞市诚颯五金电子科技有限公司

Email : sales01@dck-gd.com

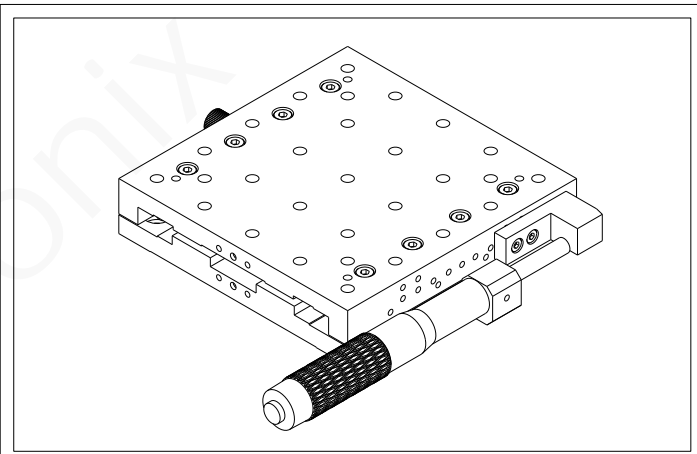
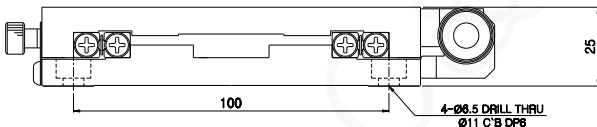
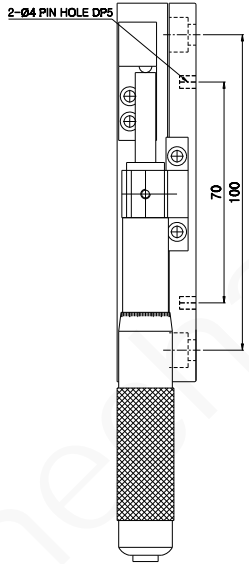
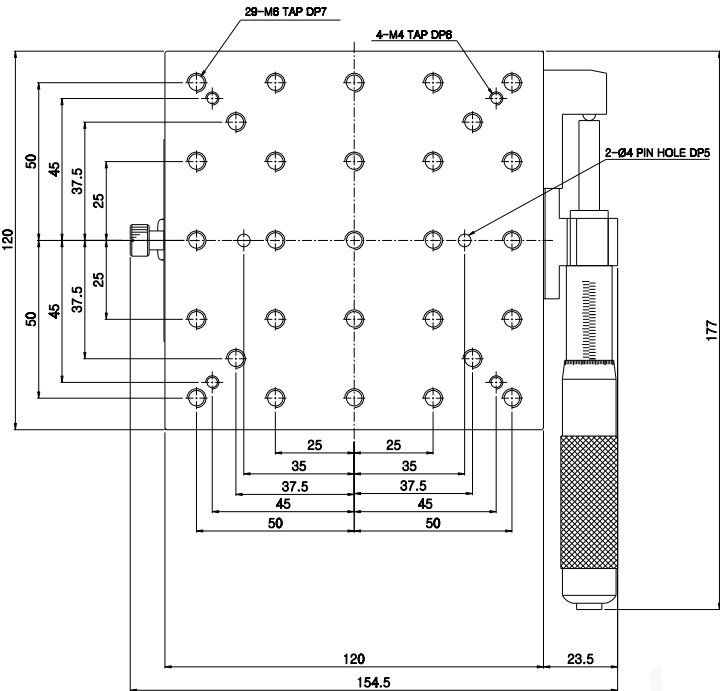

Model	JCX-120R-50
Surface Size	120x120mm
Position of Micrometer Head	Right
Travel Range	±25mm
Minimum Reading of Micrometer	10um
Guide Type	Crossed Roller Guide
Load Capacity	20Kgf
Parallelism	60um
Driving Parallelism	20um
Weight	1.5Kg
Material	Aluminum
Finish Treatment	Black Anodizing

JCX - 120R - 50

东莞市诚鲲五金电子科技有限公司