

Email : sales01@dck-gd.com

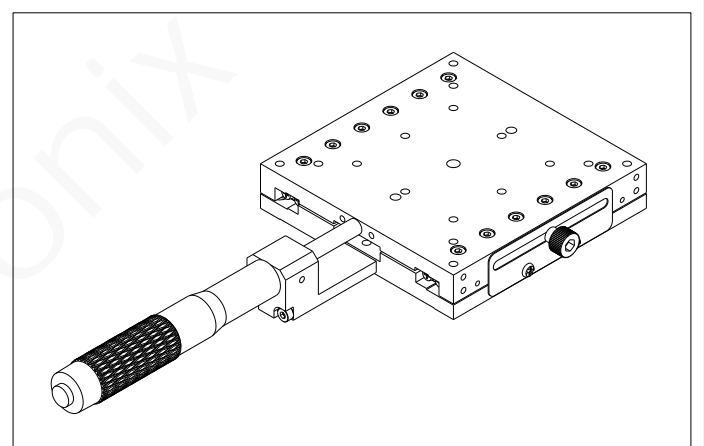
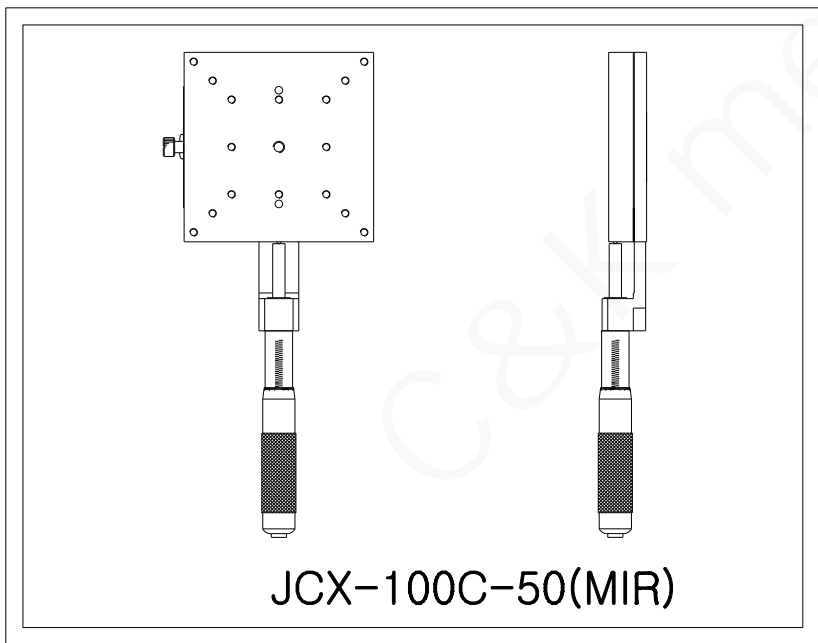
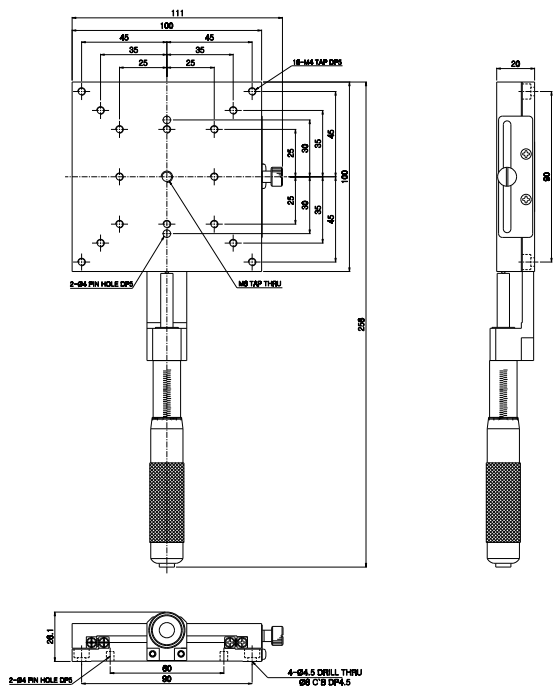

Model	JCX-100C-50
Surface Size	100x100mm
Position of Micrometer Head	Center
Travel Range	±25mm
Minimum Reading of Micrometer	10um
Guide Type	Crossed Roller Guide
Load Capacity	15Kgf
Parallelism	60um
Driving Parallelism	20um
Weight	1.15Kg
Material	Aluminum
Finish Treatment	Black Anodizing

JCX - 100C - 50
 东莞市诚颯五金电子科技有限公司

Email : sales01@dck-gd.com

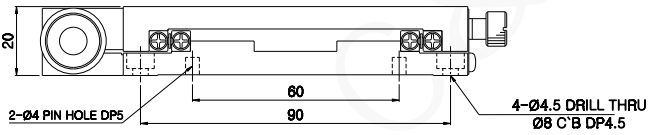
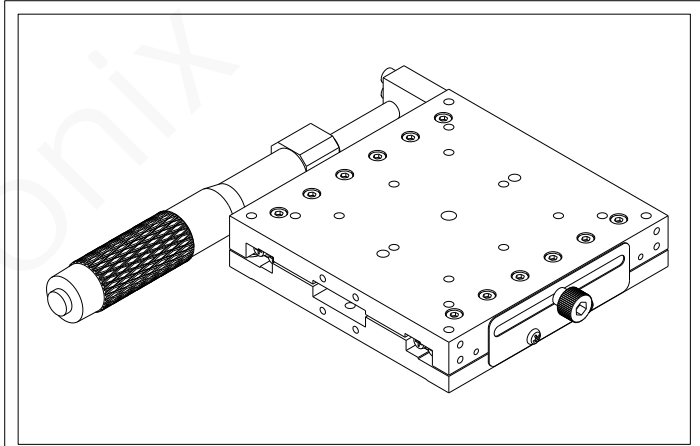
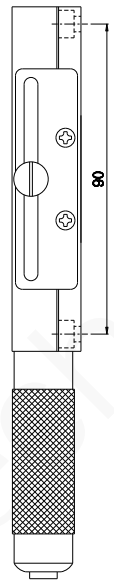
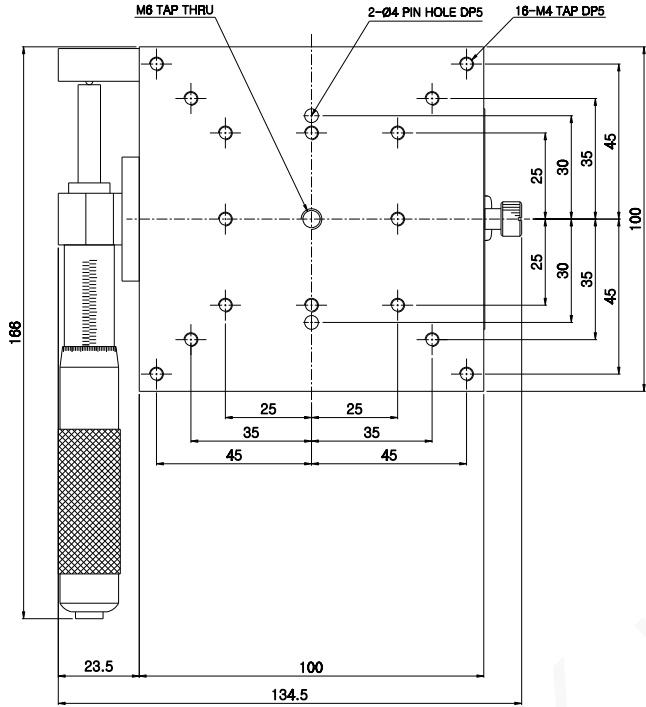

Model	JCX-100L-50
Surface Size	100x100mm
Position of Micrometer Head	Left
Travel Range	±25mm
Minimum Reading of Micrometer	10um
Guide Type	Crossed Roller Guide
Load Capacity	15Kgf
Parallelism	60um
Driving Parallelism	20um
Weight	1.2Kg
Material	Aluminum
Finish Treatment	Black Anodizing

JCX - 100L - 50
 东莞市诚鲲五金电子科技有限公司

Email: sales01@dck-gd.com

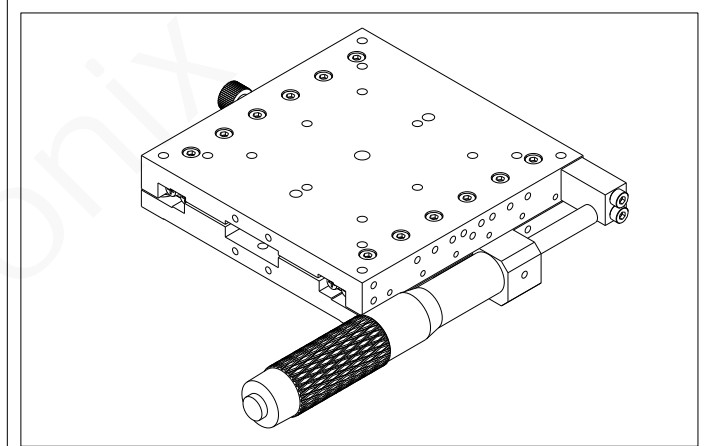
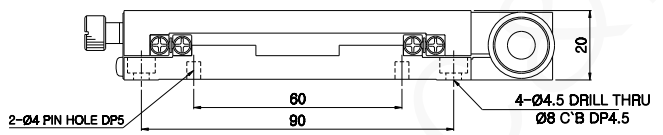
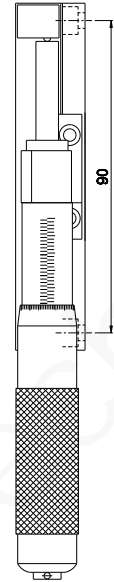
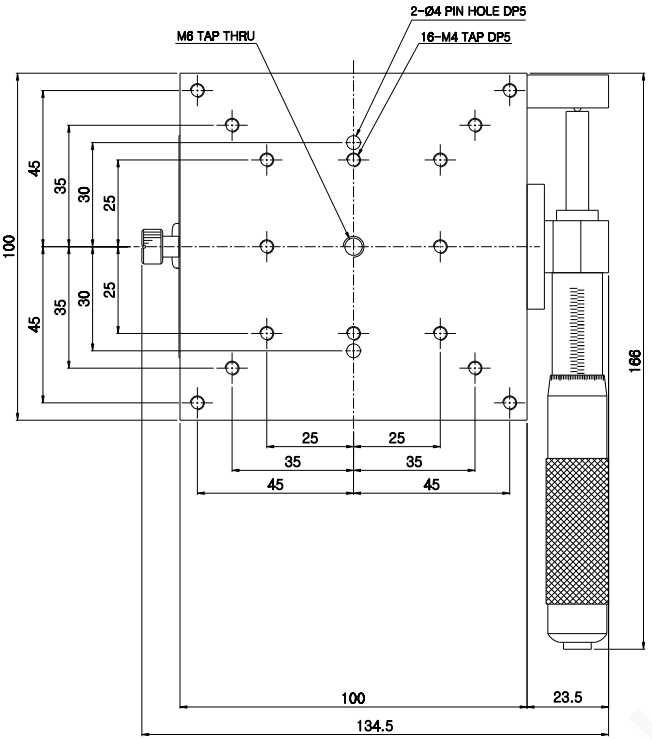

Model	JCX-100R-50
Surface Size	100x100mm
Position of Micrometer Head	Right
Travel Range	±25mm
Minimum Reading of Micrometer	10um
Guide Type	Crossed Roller Guide
Load Capacity	15Kgf
Parallelism	60um
Driving Parallelism	20um
Weight	1.2Kg
Material	Aluminum
Finish Treatment	Black Anodizing

JCX - 100R - 50
 东莞市诚鲲五金电子科技有限公司